

LOT CONSOLIDATION SURVEY

FOR

DUANE KURTH

SITUATED IN THE CITY OF AMHERST, COUNTY OF LORAIN, STATE OF OHIO, KNOWN AS BEING PART OF ORIGINAL AMHERST TOWNSHIP LOT NUMBER 17

(A)	05-00-017-000-033 NORMAN F. KURTH (PARCEL 1 & 2) INST.#2005-0066157 0.4969 OF AN ACRE (REC.) 0.5085 OF AN ACRE (CALC.)
(B)	05-00-017-000-153 NORMAN F. KURTH (PARCEL 3) INST.#2005-0066157 0.0421 OF AN ACRE (REC.) 0.0425 OF AN ACRE (CALC.)
(C)	05-00-016-101-083 ROBERT L. GREGORY & DEBRA GREGORY INST.#2001-0800322
(D)	05-00-017-000-103 AARON S. WEST INST.#2015-0547817

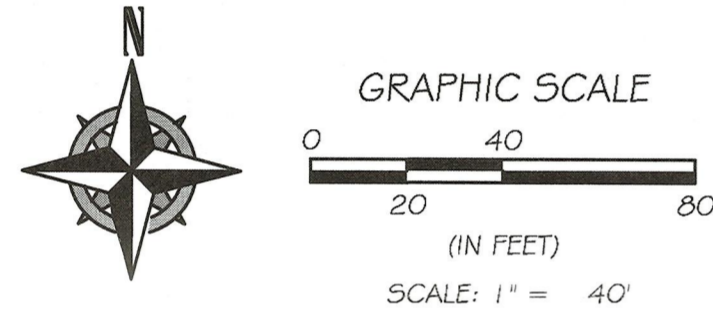

LEGEND:

- IRON PIN/PIPE FOUND AS NOTED
- 5/8" REBAR SET WITH YELLOW CAP STAMPED "RAFTER A, LTD CORNER PIN" OR GREEN CAP STAMPED "RAFTER A, LTD LINE PIN"
- ▣ MONUMENT BOX FOUND WITH IRON PIN/PIPE FOUND AS NOTED
- M.N.F. MAGNETIC NAIL/SPIKE FOUND
- M.N.S. MAGNETIC NAIL/SPIKE SET
- RAILROAD SPIKE FOUND
- P/L PROPERTY LINE
- C/L CENTERLINE
- R/W RIGHT-OF-WAY

REFERENCES

- SUBJECT & ADJACENT PARCEL RECORDINGS AS LISTED HEREON
- LORAIN COUNTY TAX MAPS (CURRENT AND 1962 MAPS)
- MAP OF SURVEY FOR MERLE D. & RUTH R. LEHMAN, C.E. PENFOUND REGISTERED SURVEYOR, DATED SEPTEMBER 12, 1951
- SURVEY FOR ALBERT J. BODMAN, J.W. WARDEN AND ASSOCIATES REGISTERED SURVEYORS, DATED SEPTEMBER 10, 1956
- PLAT OF BOUNDARY SURVEY FOR JOSEPH SEXTON JR., LAUNDON-SIMON-KELSER&ASSOC., INC. ALEX KELSER P.5.7871, DATED NOVEMBER 9, 2001
- SURVEY FOR GLEN E. BRIGHTBILL & ROBT E. REBECCA A. BEAL, LAUNDON-SIMON-CARL&ASSOC., INC. ROGER G. SIMON P.5.5101, DATED SEPTEMBER 1997
- VALLEY FOREST SUBDIVISION NO. 1, PLAT VOLUME 23 PAGE 28
- FAIRFIELD ESTATES SUBDIVISION NUMBER 1, PLAT VOLUME 51 PAGE 75

BASIS OF BEARINGS

BASIS OF BEARING IS ASSUMED AND IS USED TO DESCRIBE ANGLES ONLY. A PORTION OF THE CENTERLINE OF SOUTH LAKE STREET AND IS ASSUMED TO BE SOUTH 01° 18' 36" WEST AS SHOWN HEREON.

THIS SURVEY IS BASED UPON A FIELD SURVEY PERFORMED BY RAFTER A., LTD IN FEBRUARY OF 2022.

CHARLES AVENUE
(60' R/W)

SOUTH LAKE STREET (60' R/W)

GREEN FOREST DRIVE
(60' R/W)

VAN OAKS DRIVE (60' R/W)

VALLEY FOREST SUBDIVISION NO.3
P.V. 24 PG.23

CHARLES OAK POINT ESTATES SUBDIVISION NO.1
P.V.23 PG.77

CHARLES OAK POINT ESTATES SUBDIVISION NO.2
P.V.25 PG.64

CHARLES OAK POINT ESTATES SUBDIVISION NO.1
P.V.23 PG.77

CHARLES OAK POINT ESTATES SUBDIVISION NO.2
P.V.25 PG.64

CURVE TABLE						
CURVE #	ARC LENGTH	RADIUS	CHORD LENGTH	CHORD DIRECTION	TANGENT	DELTA
C1	40.45'(C) 40.42'(R)	158.10'(C) 161.39'(R)	40.34'(C) 40.31'(R)	S 81°01'19" E	20.34'(C) 20.32'(R)	14°39'32"(C) 14°21'00"(R)
C2	40.45'(C) 40.42'(R)	158.10'(C) 161.39'(R)	40.34'(C) 40.31'(R)	S 81°01'19" E	20.34'(C) 20.32'(R)	14°39'32"(C) 14°21'00"(R)
C3	48.13'(C) 47.93'(R)	188.10'(C) 191.39'(R)	47.99'(C) 47.81'(R)	S 81°01'19" E	24.19'(C) 24.09'(R)	14°39'32"(C) 14°21'00"(R)
C4	32.77'(C) 32.90'(R)	128.10'(C) 131.39'(R)	32.69'(C) 32.82'(R)	S 81°01'19" E	16.48'(C) 16.54'(R)	14°39'32"(C) 14°21'00"(R)
C5	55.80'(C) 55.44'(R)	218.10'(C) 221.39'(R)	55.65'(C) 55.30'(R)	S 81°01'19" E	28.05'(C) 27.87'(R)	14°39'32"(C) 14°21'00"(R)
C6	25.10'(C) 25.39'(R)	98.10'(C) 101.39'(R)	25.03'(C) 25.33'(R)	S 81°01'19" E	12.62'(C) 12.76'(R)	14°39'32"(C) 14°21'00"(R)

REV.	BY	DATE	DESCRIPTION
1	JAD	03-31-2022	ISSUE TO CLIENT

50680
APPROVED
LOI NO.
MAP NO.
DATE 8/26/22
PAGE 05-00-017-A
BY A. Carden
#22-04547



PPN: 05-00-017-000-033 & 05-00-017-000-153
LOT CONSOLIDATION SURVEY
CITY OF AMHERST, COUNTY OF LORAIN, STATE OF OHIO

RAFTER A, LTD
LAND SURVEYING • ENGINEERING • TESTING
42653 Oberlin-Elyria Road, Oberlin, Ohio 44074
440-707-4014 • www.raftera.com • info@raftera.com

DUANE KURTH
737 FORDE AVE
AMHERST, OHIO 44001

DRAWN BY: JAD
JOB No: 2755-21

CHECKED BY: BDA
SHEET 1 of 1