

RIGHT OF WAY LEGEND SHEET LOR-US 6-14.49 (LAKE RD)

CITY OF SHEFFIELD LAKE
 LORAIN COUNTY, OHIO
 ORIGINAL SHEFFIELD TOWNSHIP
 LOT NUMBERS 35 & 37
 T. 7 N., R. 17 W.,
 CONNECTICUT WESTERN RESERVE

PROJECT DESCRIPTION
 THIS PROJECT INVOLVES THE REMOVAL AND REPLACEMENT OF THE LOR-6-14.46 & LOR-6-14.88 CULVERTS. THE WORK TO BE PERFORMED INCLUDES PAVEMENT REMOVAL, ASPHALT PAVEMENT, GRADING AND NEW CULVERT INSTALLATIONS.

NOTE
 THE EXISTING AND PROPOSED RIGHT OF WAY SHALL BE REFERENCED FROM THE EXISTING CENTERLINE OF RIGHT OF WAY OF U.S. 6.

STRUCTURE KEY

- RESIDENTIAL**
- COMMERCIAL**
- OUT-BUILDING**

TYPES OF TITLE LEGEND:
 WD = WARRANTY DEED
 T = TEMPORARY EASEMENT
 CH = CHANNEL EASEMENT
 SH = STANDARD HIGHWAY EASEMENT

UTILITY OWNERS	
CITY OF SHEFFIELD LAKE WATER/SANITARY/STORM ATTN: PAT HASTINGS 4750 RICHELIEU AVE. SHEFFIELD LAKE, OH 44054 440-949-5191	COLUMBIA GAS OF OHIO ATTN: TOPE AKINMOLADUN 3101 NORTH RIDGE RD., EAST LORAIN, OH 44055 440-867-1005
CENTURYLINK ATTN: GERONIMO SALES 1730 W. 9TH STREET LORAIN, OH 44052 440-244-8330	CHARTER/SPECTRUM ATTN: GARY NAUMANN 578 TERNES LANE ELYRIA, OH 44035 216-392-7963
WIDE OPEN WEST ATTN: BOB HAMMOND 105 BLAZE INDUSTRIAL PKWY BERA, OH 44017 440-625-0349	FIRST ENERGY/OHIO EDISON ATTN: DOUG LINN 6326 LAKE AVENUE ELYRIA, OH 44035 440-326-3269
NOTE: THE LOCATION OF THE UNDERGROUND UTILITIES SHOWN ON THE PLANS ARE OBTAINED FROM THE OWNER OF THE UTILITIES AS REQUIRED BY SECTION 153.64. O.R.C.	

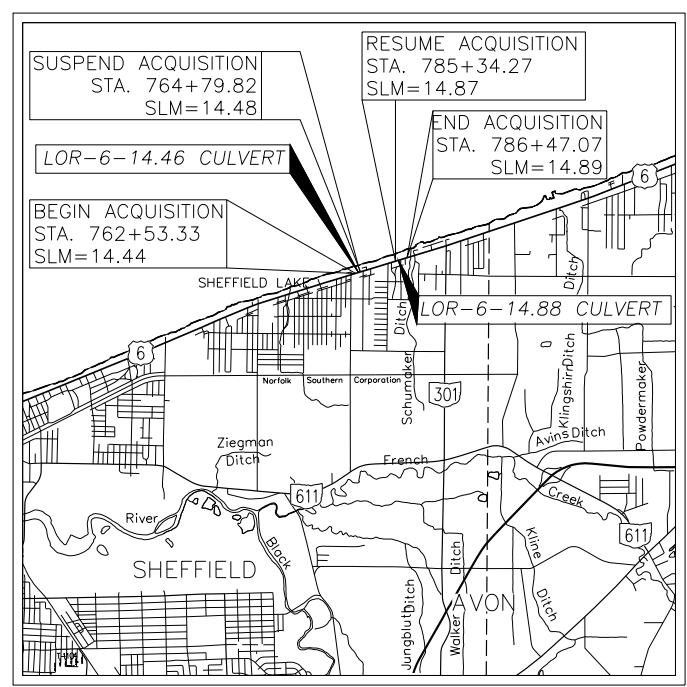

LOCATION MAP

LOR-6-14.46 - LATITUDE: 41°29'40" LONGITUDE: 82°05'32"
 LOR-6-14.88 - LATITUDE: 41°29'46" LONGITUDE: 82°05'05"

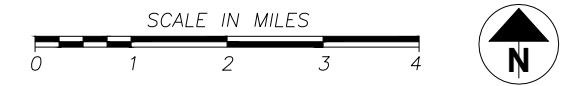

PLANS PREPARED BY:

FIRM NAME : BRAMHALL ENGINEERING & SURVEYING COMPANY
 R/W DESIGNER: JAMES T. SCOTT JR., P.E.
 R/W REVIEWER: AMY M. KELLY, P.S.
 FIELD REVIEWER: KEITH ROHAL
 PRELIMINARY FIELD REVIEW DATE: JUNE 29, 2020
 TRACINGS FIELD REVIEW DATE: SEPTEMBER 16, 2020
 OWNERSHIP UPDATED BY: AMY M. KELLY, P.S.
 DATE COMPLETED: SEPTEMBER 16, 2020
 PLAN COMPLETION DATE: NOVEMBER 16, 2020

INDEX OF SHEETS:

- LEGEND SHEET..... 1
- CENTERLINE PLAT & MONUMENTATION..... 2 - 3
- PROPERTY MAP..... 4
- SUMMARY OF ADDITIONAL R/W..... 5
- RIGHT OF WAY DETAILS..... 6 - 7

PROJECT CONTROL

COORDINATE SYSTEM: OHIO STATE PLANE, NORTH ZONE (3401)
 HORIZONTAL DATUM: NAD83 (2011 ADJUSTMENT)
 GRID TO GROUND MULTIPLIER: 1.000056164
 COMBINED SCALE FACTOR: 0.999943839
 PROJECT ADJUSTMENT FACTOR (STATE PLANE GRID (METERS) TO PROJECT GROUND (US SURVEY FEET): 3.281128608
 ENGLISH TO METRIC CONVERSION: 3.28083333

I, AMY M. KELLY, P. S. HAVE CONDUCTED A SURVEY OF THE EXISTING CONDITIONS FOR THE CITY OF SHEFFIELD LAKE IN MAY AND JUNE OF 2020. THE RESULTS OF THAT SURVEY ARE CONTAINED HEREIN. THE HORIZONTAL COORDINATES EXPRESSED HEREIN ARE BASED ON THE OHIO STATE PLANE COORDINATES SYSTEM NORTH ZONE ON NAD 83 (2011 ADJUSTMENT) DATUM. THE PROJECT COORDINATES (US SURVEY FEET) ARE RELATIVE TO STATE PLANE GROUND COORDINATES (US SURVEY FEET) BY A COMBINED SCALE FACTOR OF 0.999943839 ABOUT POINT 4. ELEVATIONS OF PROJECT CONTROL POINTS AND BENCHMARKS ARE BASED ON GEOID 12-A OF THE NAVD88 DATUM AND WERE ESTABLISHED BY UTILIZING THE ODOT VRS RTK NETWORK. AS A PART OF THIS PROJECT I HAVE REESTABLISHED THE LOCATIONS OF THE EXISTING PROPERTY LINES AND THE EXISTING CENTERLINE OF RIGHT OF WAY FOR PROPERTY TAKES CONTAINED HEREIN. AS A PART OF THIS PROJECT I HAVE ESTABLISHED THE PROPOSED PROPERTY LINES, CALCULATED THE GROSS TAKE, PRESENT ROADWAY OCCUPIED (PRO), NET TAKE AND NET RESIDUE; AS WELL AS PREPARED THE LEGAL DESCRIPTIONS NECESSARY TO ACQUIRE THE PARCELS AS SHOWN HEREIN. AS A PART OF THIS WORK I HAVE SET RIGHT OF WAY MONUMENTS AT THE PROPERTY CORNERS, PROPERTY LINE INTERSECTION, POINTS ALONG THE RIGHT OF WAY AND/OR ANGLE POINTS ON THE RIGHT OF WAY, SECTION CORNERS AND OTHER POINTS AS SHOWN HEREIN. ALL OF MY WORK CONTAINED HEREIN WAS CONDUCTED IN ACCORDANCE WITH OHIO ADMINISTRATIVE CODE 4733-37 COMMONLY KNOWN AS "MINIMUM STANDARDS FOR BOUNDARY SURVEYS IN THE STATE OF OHIO" UNLESS NOTED. THE WORDS I AND MY AS USED HEREIN ARE TO MEAN EITHER MYSELF OR SOMEONE WORKING UNDER MY DIRECT SUPERVISION.

CONVENTIONAL SYMBOLS

- | | |
|---|---|
| County Line -----
Township Line -----
Section Line -----
Corporation Line ----- or -----
Fence Line (Ex) -----x-----x----- (Pr) -----x-----
Center Line -----
Right of Way (Ex) -----Ex R/W-----
Right of Way (Pr) -----R/W-----
Standard Highway Ease.(Ex) -----Ex SH-----
Standard Highway Ease.(Pr) -----SH-----
Temporary Right of Way -----TMP-----
Channel Ease. (Pr) -----CH-----
Utility Ease. (Ex) -----Ex U-----
Railroad ----- or -----
Guardrail (Ex) -----o-----o-----o----- (Pr) -----o-----o-----o-----
Construction Limits -----
Edge of Pavement (Ex) -----
Edge of Pavement (Pr) -----
Edge of Shoulder (Ex) -----
Edge of Shoulder (Pr) -----
Ditch / Creek (Ex) -----
Ditch / Creek (Pr) ----- | Overhead Electric (Ex) -----OH-E-----
Overhead Telephone (Ex) -----OH-T-----
Overhead Combined (Ex) -----OH-Comb-----
Waterline (Ex) -----W-----
Waterline (Pr) -----W-----
Tree Line (Ex) -----
Ownership Hook Symbol -----, Example -----
Property Line Symbol -----, Example -----
Break Line Symbol -----, Example -----
Tree (Pr) -----, Tree (Ex) -----, Shrub (Ex) -----
Tree (Remove) -----, Shrub (Remove) -----
Evergreen (Ex) -----, Stump -----
Evergreen (Remove) -----, Stump (Remove) -----
Wetland (Pr) -----, Soil Boring -----
Post (Ex) -----, Mailbox (Ex) -----, Mailbox (Pr) -----
Light (Ex) -----, Telephone Marker (Ex) -----TEL-----
Fire Hydrant (Ex) -----, Water Meter (Ex) -----
Water Valve (Ex) -----, Utility Valve Unknown (Ex.) -----
Water Valve (Pr) -----
Telephone Pole (Ex) -----, Power Pole (Ex) -----
Light Pole (Ex) -----, Light and Power Pole (Ex) ----- |
|---|---|

AMY M. KELLY, PROFESSIONAL LAND SURVEYOR NO. 8469

DATE: 11/13/2020

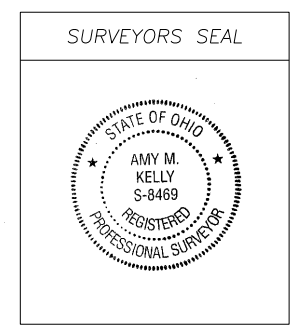

J:\123300-Sheffield Lake\12-3300-39 LOR-US 6-14.49 PID 111579\Drawings\Sheets\RW_01_LEGEND SHEET.dwg, Plotted: Nov 13, 2020 - 1:56pm

LOR-US 6-14.49 (LAKE RD)

CITY OF SHEFFIELD LAKE
LORAIN COUNTY, OHIO
ORIGINAL SHEFFIELD TOWNSHIP
LOT NUMBERS 35 & 37
T. 7 N., R. 17 W.,
CONNECTICUT WESTERN RESERVE

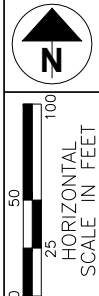

PID NO. **111579**
R/W DESIGNER: JTS
R/W REVIEWER: AMK

CENTERLINE PLAT

LOR-US 6-14.49
(LAKE RD)

1 / 2
2 / 7
26
31

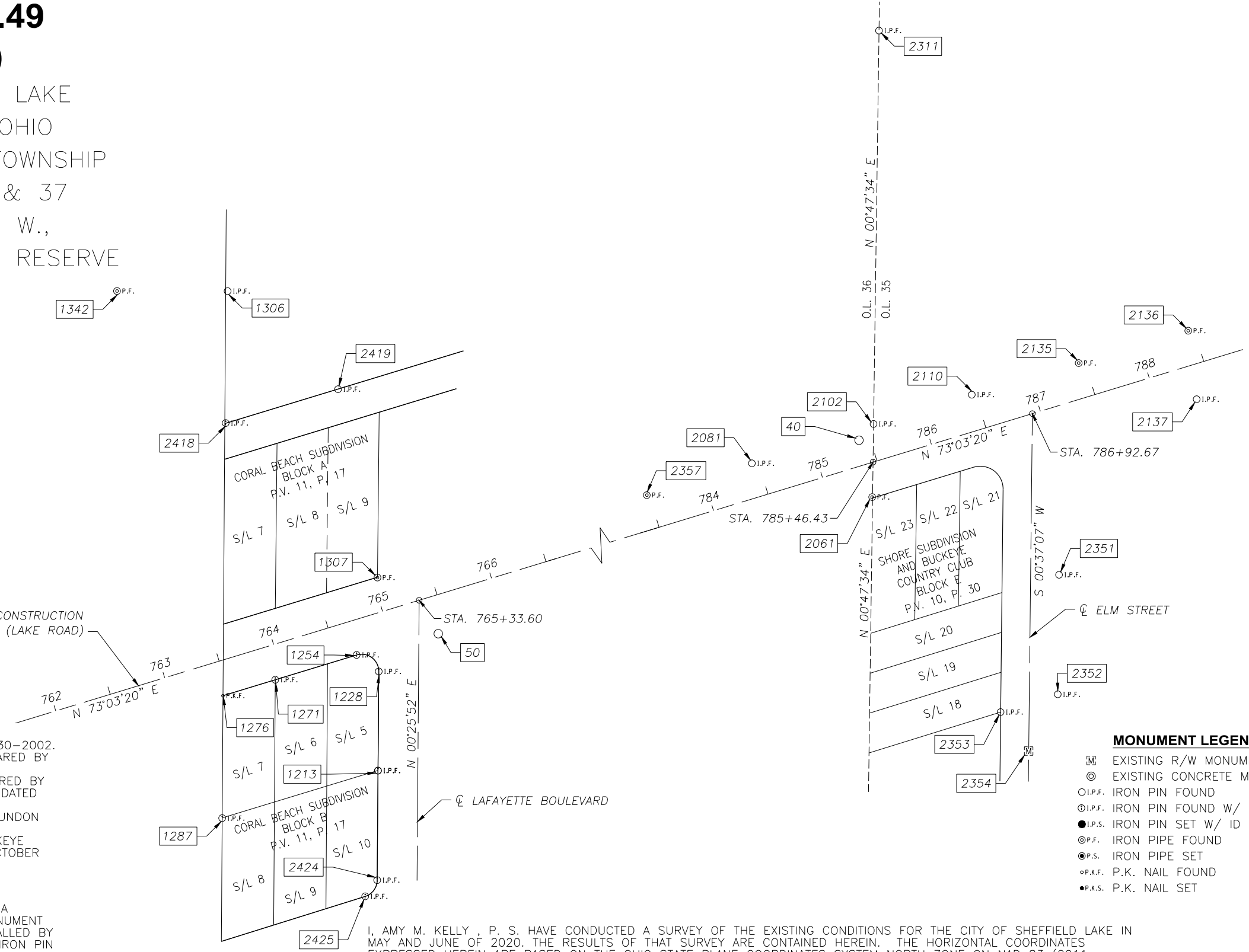

BASIS OF CENTERLINE AND RIGHT OF WAY:

THE CENTERLINE AND RIGHT-OF-WAY OF U.S. ROUTE 6 WERE DETERMINED BY UTILIZING EXISTING RIGHT-OF-WAY & PROPERTY PINS, SURVEY RECORDS, AND DEEDS.

BASIS OF BEARINGS:

BEARINGS ARE RELATIVE TO GRID NORTH OF THE OHIO STATE PLANE COORDINATE SYSTEM, NORTH ZONE (3401), NAD83 (2011 ADJUSTMENT), AND CORRECTED UTILIZING ODOT VRS (VIRTUAL REFERENCE SYSTEM).

REFERENCES:

- SUBMERGED LAND LEASE FOR STEPHEN J. DRISCOLL JR. PREPARED BY ANDRASSY ENGINEERING, LTD. DATED 05-30-2002.
- SUBMERGED LAND LEASE FOR JAMES F. STEWART. PREPARED BY ANDRASSY ENGINEERING, LTD. DATED 05-30-2002.
- BOUNDARY SURVEY FOR JOY Y. & GAR W. AKINS PREPARED BY BRAMHALL ENGINEERING AND SURVEYING COMPANY, INC. DATED 03-19-2001.
- CORAL BEACH SUBDIVISION PREPARED BY WARDEN & LAUNDON DATED 03-15-1924.
- THE BORDER CITIES CO'S SHORE SUBDIVISION AND BUCKEYE COUNTRY CLUB PREPARED BY C.W. COURTNEY DATED OCTOBER 1921.

NOTE:

- SETTING OF ALL MONUMENTS SHALL BE PERFORMED BY A SURVEYOR REGISTERED IN THE STATE OF OHIO. THE MONUMENT ASSEMBLIES AND REFERENCE MONUMENTS WILL BE INSTALLED BY THE CONTRACTOR AT THE TIME OF CONSTRUCTION. THE IRON PIN AND CAP (WHEN REQUIRED) ARE TO BE INSTALLED BY THE CONTRACTOR'S SURVEYOR.

CHANGES OR ALTERATIONS TO THE LOCATION OF ANY MONUMENTS SHOWN IN THIS TABLE, REQUIRE PRIOR APPROVAL FROM THE DISTRICT REAL ESTATE ADMINISTRATOR OF THE OHIO DEPARTMENT OF TRANSPORTATION. IN THE EVENT THAT CHANGES OR ALTERATIONS ARE APPROVED, A REVISED CENTERLINE PLAT WITH THE NEW LOCATIONS SHALL BE RECORDED IN THE APPLICABLE COUNTY RECORDS AND THE OHIO DEPARTMENT OF TRANSPORTATION. SPECIFICATIONS FOR MONUMENT ASSEMBLIES, REFERENCE MONUMENTS AND RIGHT OF WAY MONUMENTS ARE SHOWN ON STANDARD CONSTRUCTION DRAWING RM-1.1.

I, AMY M. KELLY, P. S. HAVE CONDUCTED A SURVEY OF THE EXISTING CONDITIONS FOR THE CITY OF SHEFFIELD LAKE IN MAY AND JUNE OF 2020. THE RESULTS OF THAT SURVEY ARE CONTAINED HEREIN. THE HORIZONTAL COORDINATES EXPRESSED HEREIN ARE BASED ON THE OHIO STATE PLANE COORDINATES SYSTEM NORTH ZONE ON NAD 83 (2011 ADJUSTMENT) DATUM. THE PROJECT COORDINATES (US SURVEY FEET) ARE RELATIVE TO STATE PLANE GROUND COORDINATES (US SURVEY FEET) BY A COMBINED SCALE FACTOR OF 0.999943839 ABOUT POINT 4. ELEVATIONS OF PROJECT CONTROL POINTS AND BENCHMARKS ARE BASED ON GEOID 12-A OF THE NAVD88 DATUM AND WERE ESTABLISHED BY UTILIZING THE ODOT VRS RTK NETWORK. AS A PART OF THIS PROJECT I HAVE REESTABLISHED THE LOCATIONS OF THE EXISTING PROPERTY LINES AND THE EXISTING CENTERLINE OF RIGHT OF WAY FOR PROPERTY TAKES CONTAINED HEREIN. AS A PART OF THIS PROJECT I HAVE ESTABLISHED THE PROPOSED PROPERTY LINES, CALCULATED THE GROSS TAKE, PRESENT ROADWAY OCCUPIED (PRO), NET TAKE AND NET RESIDUE; AS WELL AS PREPARED THE LEGAL DESCRIPTIONS NECESSARY TO ACQUIRE THE PARCELS AS SHOWN HEREIN. AS A PART OF THIS WORK I HAVE SET RIGHT OF WAY MONUMENTS AT THE PROPERTY CORNERS, PROPERTY LINE INTERSECTION, POINTS ALONG THE RIGHT OF WAY AND/OR ANGLE POINTS ON THE RIGHT OF WAY, SECTION CORNERS AND OTHER POINTS AS SHOWN HEREIN. ALL OF MY WORK CONTAINED HEREIN WAS CONDUCTED IN ACCORDANCE WITH OHIO ADMINISTRATIVE CODE 4733-37 COMMONLY KNOWN AS "MINIMUM STANDARDS FOR BOUNDARY SURVEYS IN THE STATE OF OHIO" UNLESS NOTED. THE WORDS I AND MY AS USED HEREIN ARE TO MEAN EITHER MYSELF OR SOMEONE WORKING UNDER MY DIRECT SUPERVISION.

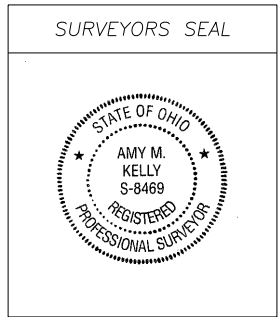

Amy M. Kelly
AMY M. KELLY PROFESSIONAL SURVEYOR NO. 8469

DATE: 11/13/2020

RECEIVED _____	20__
RECORDED _____	20__
BOOK _____	PAGE _____
COUNTY RECORDER	

J:\123300-Sheffield Lake\12-3300-39 LOR-US 6-14.49 PID 111579\Drawings\Sheets\RM_02_CENTERLINE PLAT.dwg, Plotted: Nov 13, 2020 - 2:04pm

J:\123300-Sheffield Lake\12-3300-39_LOR-US 6-14.49 PID 111579\Drawings\Sheets\RM_02_CENTERLINE_PLAT.dwg, Plotted: Nov 13, 2020 - 1:36pm

LOR-6-14.49								PID: 111579										
PROJECT GROUND COORDINATES - US SURVEY FEET								PROJECT CONTROL POINTS				STATE PLANE GRID COORDINATES					MONUMENTS TO BE SET DURING CONSTRUCTION	
Project coordinates (U.S. Survey Feet) are relative to State Plane Grid coordinates (meters) by a Project Adjustment Factor of: 3.281128608												Horiz. Datum: NAD83 (2011 ADJUSTMENT) Ohio State Plane, North Zone (3401) Vert. Datum: NAVD88					ITEM 623E38500 MONUMENT ASSEMBLY	
C/L of Right of Way								EXISTING RIGHT OF WAY AND BOUNDARY MONUMENTS				Ohio State Plane, North Zone (3401)						
NAME	STATION	OFFSET (US FT)	RT/LT	NORTH (US FT)	EAST (US FT)	ELEV (US FT)	FEATURE					DESCRIPTION	NAME	NORTH (m)	EAST (m)	ORTHO HT (m)		
50	765+41.11	33.00'	RT	666757.036	2082198.563	595.00	CNPT	5/8" REBAR WITH RED BRAMHALL CONTROL CAP SET	50	203209.6622	634598.2775	181.356	666697.0333	2082011.1822				
40	785+40.27	21.92'	LT	666121.847	2080302.207	595.30	CNPT	5/8" REBAR WITH RED BRAMHALL CONTROL CAP SET	40	203016.0736	634020.3191	181.448	666061.9015	2080114.9969				
EXISTING MONUMENTATION CENTERLINE OF RIGHT OF WAY US ROUTE 6								EXISTING RIGHT OF WAY AND BOUNDARY MONUMENTS				Ohio State Plane, North Zone (3401)						
NAME	STATION	OFFSET (US FT)	RT/LT	NORTH (US FT)	EAST (US FT)	ELEV (US FT)	FEATURE					DESCRIPTION	NAME	NORTH (m)	EAST (m)	ORTHO HT (m)		
1343	761+76.36	295.77'	RT	665764.183	2080029.870	595.15	CMON	CONCRETE MONUMENT	1343	202907.0672	633937.3181	181.402	665704.2697	2079842.6844				
1287	763+12.37	132.72'	RT	665959.793	2080112.457	594.66	IPID	5/8" PIN CAPPED CASEY	1287	202966.6839	633962.4884	181.253	665899.8621	2079925.2639				
1276	763+44.40	30.03'	RT	666067.365	2080113.168	594.58	PK	PK NAIL	1276	202999.4690	633962.7051	181.228	666007.4244	2079925.9749				
1342	763+59.01	337.19'	LT	666422.900	2080020.120	592.62	IPIPE	1" IRONPIPE	1342	203107.8265	633934.3465	180.631	666362.9274	2079832.9352				
1271	763+92.39	30.01'	RT	666081.365	2080159.067	594.10	IPID	5/8" PIN CAPPED CASEY	1271	203003.7358	633976.6939	181.082	666021.4231	2079971.8697				
2425	764+12.49	235.04	RT	665891.091	2080238.049	595.76	IPID	5/8" PIN CAPPED CASEY	2425	202945.7454	634000.7654	181.588	665831.1663	2080050.8446				
2418	764+16.48	198.45	LT	666306.931	2080115.521	593.25	IPID	5/8" PIN CAPPED RESAR	2418	203072.4822	633963.4222	180.823	666246.9688	2079928.3277				
2424	764+26.72	224.54	RT	665905.287	2080248.598	596.12	IPID	5/8" PIN CAPPED CASEY	2424	202950.0719	634003.9805	181.698	665845.3610	2080061.3927				
1306	764+51.91	308.84'	LT	666422.850	2080117.249	593.62	IPIN	1/2" IRON PIN	1306	203107.8112	633963.9488	180.936	666362.8774	2079930.0555				
1213	764+55.40	132.71'	RT	666001.491	2080249.274	595.41	IPID	5/8" PIN CAPPED CASEY	1213	202979.3923	634004.1865	181.481	665941.5563	2080062.0686				
1254	764+67.09	29.96'	RT	666103.184	2080230.509	594.23	IPID	5/8" PIN CAPPED CASEY	1254	203010.3856	633998.4675	181.122	666043.2402	2080043.3053				
1228	764+81.44	49.50'	RT	666088.679	2080249.930	594.93	IPID	5/8" PIN CAPPED CASEY	1228	203005.9649	634004.3865	181.335	666028.7365	2080062.7246				
1307	765+04.42	29.75'	LT	666171.182	2080248.814	594.45	IPIPE	1" IRON PIPE	1307	203031.1096	634004.0463	181.189	666111.232	2080061.609				
2419	765+19.56	198.12	LT	666336.654	2080214.224	594.17	IPIN	1/2" IRON PIN	2419	203081.5410	633993.5042	181.103	666276.689	2080027.022				
2357	783+47.92	30.16'	LT	666708.850	2082012.163	594.18	IPIN	1" IRON PIN	2357	203194.9764	634541.4678	181.106	666648.852	2081824.799				
2081	784+44.36	29.98'	LT	666736.796	2082104.474	594.73	IPIN	1/2" IRON PIN	2081	203203.4936	634569.6017	181.274	666676.795	2081917.102				
2061	785+36.76	29.18'	RT	666707.133	2082210.104	594.17	IPIPE	3/4" IRON PIPE	2061	203194.4531	634601.7949	181.103	666647.135	2082022.722				
2102	785+56.64	31.94'	LT	666771.387	2082211.309	593.83	IPIN	1/2" IRON PIN	2102	203214.0360	634602.1622	181.000	666711.3830	2082023.9271				
2353	785+89.58	242.75	RT	666518.221	2082322.878	596.59	IPID	5/8" PIN CAPPED BRAMHALL 8073	2353	203136.8778	634636.1654	181.841	666458.240	2082135.486				
2354	786+03.16	282.65	RT	666484.012	2082347.495	596.08	MONBOX	MOUMENT BOX WITH 5/8" PIN CAPPED	2354	203126.4518	634643.6680	181.686	666424.034	2082160.101				
2352	786+42.15	242.45'	RT	666533.831	2082373.078	596.56	IPID	5/8" PIN CAPPED BRAMHALL 8073	2352	203141.6353	634651.4650	181.832	666473.848	2082185.682				
2110	786+46.64	31.40'	LT	666797.106	2082297.557	594.61	IPIN	5/8" IRON PIN	2110	203221.8744	634628.4482	181.237	666737.100	2082110.167				
2311	786+61.94	361.14'	LT	667116.984	2082216.092	591.51	IPIN	1/2" IRON PIN	2311	203319.3647	634603.6199	180.293	667056.949	2082028.710				
2351	786+73.85	142.31'	RT	666638.859	2082374.212	596.23	IPID	5/8" PIN CAPPED KELSEY 7821	2351	203173.6450	634651.8106	181.731	666578.867	2082186.815				
2135	787+44.53	30.61'	LT	666824.879	2082391.428	594.28	IPIPE	1" IRON PIPE	2135	203230.3389	634657.0576	181.137	666764.870	2082204.030				
2137	788+34.37	30.00'	RT	666793.080	2082495.027	595.11	IPIN	5/8" IRON PIN	2137	203220.6474	634688.6318	181.390	666733.074	2082307.620				
2136	788+44.86	29.76'	LT	666853.303	2082487.65	594.22	IPIPE	1" PIPE	2136	203239.0018	634686.3838	181.119	666793.292	2082300.244				
PROJECT ADJUSTMENT FACTOR BASED ON: UNITLESS FACTOR 1.000056164 State Plane Grid to Project Ground (same units) PROJ. ADJ. FACTOF 3.281128608 State Plane Grid (meters) to Project Ground (US Survey Feet) ENG./METRIC CONV 3.28083333 US Survey foot to meters conversion factor								Unitless Factor: The Grid to Ground Multiplier for the project was computed by taking the inverse of the combined scale factor for.				TOTAL MONUMENTS - QUANTITY CARRIED TO GENERAL SUMMARY ITEM 623					0	
PROJECT coordinates are scaled from GRID coordinates about the Ohio North Zone grid point N=0, E=0.								Primary Project Control: Horizontal control was positioned with a minimum of 5 VRS-derived GNSS observations. Vertical control was established by differential leveling. All positions are in conformance to the ODOT Surveying and Mapping Specifications.										
PROJECT GROUND COORDINATES - US SURVEY FEET								PROPOSED RIGHT OF WAY MONUMENTS				STATE PLANE GRID COORDINATES					MONUMENTS TO BE RESET AFTER CONSTRUCTION	
Project coordinates (U.S. Survey Feet) are relative to State Plane Grid coordinates (meters) by a Project Adjustment Factor of: 3.281128608												Horiz. Datum: NAD83 (2011 ADJUSTMENT) Ohio State Plane, North Zone (3401) Vert. Datum: NAVD88					ITEM 623E40520 RIGHT OF WAY MONUMENT	
NAME	STATION	OFFSET (US FT)	RT/LT	NORTH (US FT)	EAST (US FT)	ELEV (US FT)	FEATURE	DESCRIPTION	NAME	NORTH (m)	EAST (m)	ORTHO HT (m)	NORTH (US FT)	EAST (US FT)				
9000	762+53.33	0.00	-	666069.545	2080017.296	0.00	PKS	PK NAIL SET	9000	203000.1332	633933.4859	0.000	666009.604	2079830.112				
9001	762+59.54	37.00	RT	666035.960	2080034.018	0.00	IPINS	5/8" X 30" REBAR WITH A CAP STAMPED "BRAMHALL 8073"	9001	202989.8976	633938.5824	0.000	665976.022	2079846.832				
9002	762+61.13	25.00	LT	666095.732	2080017.469	0.00	IPINS	5/8" X 30" REBAR WITH A CAP STAMPED "BRAMHALL 8073"	9002	203008.1144	633933.5387	0.000	666035.789	2079830.285				
9003	762+63.00	31.00	LT	666102.017	2080017.511	0.00	IPINS	5/8" X 30" REBAR WITH A CAP STAMPED "BRAMHALL 8073"	9003	203010.0299	633933.5513	0.000	666042.073	2079830.326				
9004	762+63.39	25.00	RT	666048.563	2080034.211	0.00	IPINS	5/8" X 30" REBAR WITH A CAP STAMPED "BRAMHALL 8073"	9004	202993.7387	633938.6410	0.000	665988.624	2079847.025				
9005	762+71.43	0.00	-	666074.820	2080034.612	0.00	PKS	PK NAIL SET	9005	203001.7410	633938.7632	0.000	666014.879	2079847.425				
9006	763+35.67	31.00	LT	666123.195	2080087.023	0.00	IPINS	5/8" X 30" REBAR WITH A CAP STAMPED "BRAMHALL 8073"	9006	203016.4845	633954.7367	0.000	666063.249	2079899.832				
9007	763+37.54	37.00	LT	666129.480	2080087.065	0.00	IPINS	5/8" X 30" REBAR WITH A CAP STAMPED "BRAMHALL 8073"	9007	203018.4000	633954.7494	0.000	666069.534	2079899.874				
9008	763+42.23	37.00	RT	666060.060	2080113.120	0.00	IPINS	5/8" X 30" REBAR WITH A CAP STAMPED "BRAMHALL 8073"	9008	202997.2426	633962.6903	0.000	666000.120	2079925.927				
9009	763+53.77	0.00	-	666098.817	2080113.376	0.00	PKS	PK NAIL SET	9009	203009.0548	633962.7684	0.000	666038.874	2079926.183				
9010	763+63.13	30.00	LT	666130.242	2080113.584	0.00	IPINS	5/8" X 30" REBAR WITH A CAP STAMPED "BRAMHALL 8073"	9010	203018.6322	633962.8317	0.000	666070.296	2079926.390				
9011	763+65.31	37.00	LT	666137.575	2080113.632	0.00	IPINS	5/8" X 30" REBAR WITH A CAP STAMPED "BRAMHALL 8073"	9011	203020.8669	633962.8465	0.000	666077.628	2079926.439				
9012	763+90.23	37.00	RT	666074.050	2080159.036	0.00	IPINS	5/8" X 30" REBAR WITH A CAP STAMPED "BRAMHALL 8073"	9012	203001.5062	633976.6844	0.000	666014.108	2079971.839				
9013	764+38.23	37.00	RT	666088.039	2080204.952	0.00	IPINS	5/8" X 30" REBAR WITH A CAP STAMPED "BRAMHALL 8073"	9013	203005.7698	633990.6784	0.000	666028.096	2080017.751				
9014	764+79.82	37.00	RT	666100.160	2080244.737	0.00	IPINS	5/8" X 30" REBAR WITH A CAP STAMPED "BRAMHALL 8073"	9014	203009.4641	634002.8037	0.000	666040.217	2080057.532				
9015	765+33.60	0.00	-	666151.229	2080285.402	0.00	PKS	PK NAIL SET	9015	203025.0284	634015.1972	0.000	666091.281	2080098.193				
9016	785+46.43	0.00	-	666737.859	2082210.845	0.00	PKS	PK NAIL SET	9016	203203.8175	634602.0208	0.000	666677.858	2082023.463				
9017	785+35.23	35.00	RT	666701.116	2082210.337	0.00	IPINS	5/8" X 30" REBAR WITH A CAP STAMPED "BRAMHALL 8073"	9017	203192.6191	634601.8658	0.000	666641.118	2082022.955				
9018	785+73.81	41.00	RT	666706.620	2082248.990	0.00	IPINS	5/8" X 30" REBAR WITH A CAP STAMPED "BRAMHALL 8073"	9018	203194.2968	634613.6463	0.000	666646.622	2082061.605				
9019	785+75.73	35.00	RT	666712.919	2082249.077	0.00	IPINS	5/8" X 30" REBAR WITH A CAP STAMPED "BRAMHALL 8073"	9019	203196.2165	634613.6730	0.000	666652.920	2082061.692				
9020	786+13.81	41.00	RT	666718.278	2082287.254	0.00	IPINS	5/8" X 30" REBAR WITH A CAP STAMPED "BRAMHALL 8073"	9020	203197.8498	634625.3080	0.000	666658.279	2082099.865				
9021	786+15.73	35.00	RT	666724.577	2082287.341	0.00	IPINS	5/8" X 30" REBAR WITH A CAP STAMPED "BRAMHALL 8073"	9021	203199.7695	634625.3346	0.000	666664.577	2082099.952				
9022	786+42.87	35																

LOR-US 6-14.49 (LAKE RD)

CITY OF SHEFFIELD LAKE
LORAIN COUNTY, OHIO
ORIGINAL SHEFFIELD
TOWNSHIP LOT 35

03-00-036-101-014
RICHARD & LINDA ACKERMAN
D.V. 1184, P. 353
4981 LAKE ROAD
RESIDENTIAL

SUSAN A. WILLIAMS AND
GAGE B. WILLIAMS
(VACANT LAND)
INST. #2006-0125614
RESIDENTIAL

03-00-035-101-024
STEPHEN J. DRISCOLL JR. &
PAT S. DRISCOLL
4995 LAKE ROAD
INST. #2002-0857381
RESIDENTIAL

03-00-036-117-008 APPROX. 3.0'
ADRIAN LINDSEY AND JULIE B.
LINDSEY
4980 LAKE ROAD
INST. #2006-0148359
RESIDENTIAL

03-00-035-103-001
ALAN RAY HAINES
(VACANT LAND)
O.R. VOL. 110,
P. 434
SUBLOT 23
RESIDENTIAL

03-00-035-103-002
ALAN RAY HAINES
(VACANT LAND)
O.R. VOL. 110, P. 428
SUBLOT 22
RESIDENTIAL

03-00-035-103-003
ALAN RAY HAINES
(VACANT LAND)
O.R. VOL. 110, P. 430
SUBLOT 21
RESIDENTIAL

03-00-035-104-001
JASON C & JENNIFER C WEEKLEY
5000 LAKE ROAD
INST. #2009-0301510
RESIDENTIAL

J:\123300-Sheffield Lake\12-3300-39 LOR-US 6-14.49 PID 111579\Drawings\Sheets\RW_05_RIGHT OF WAY DETAIL SHEET.dwg, Plotted: Nov 13, 2020 - 1:38pm

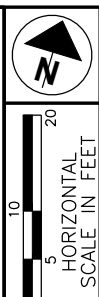
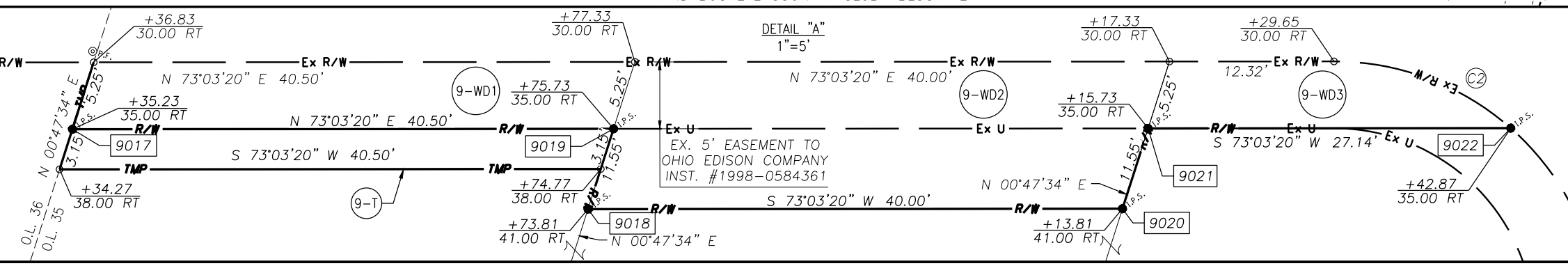
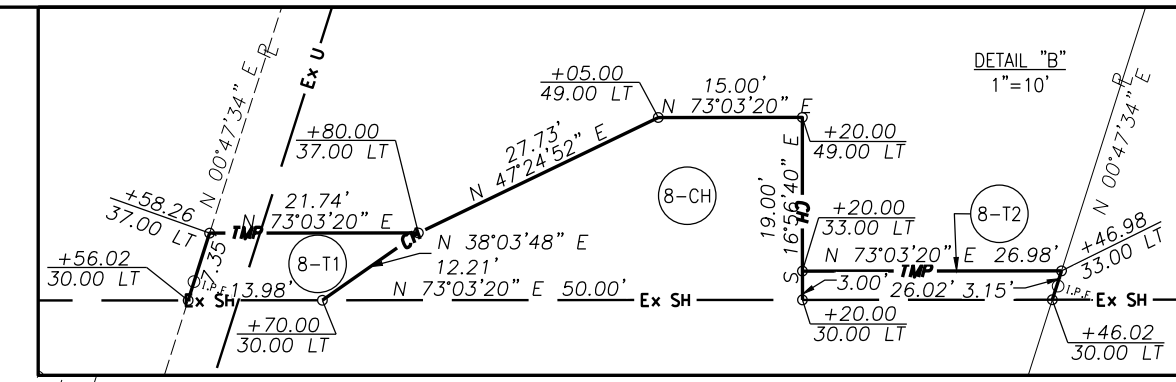
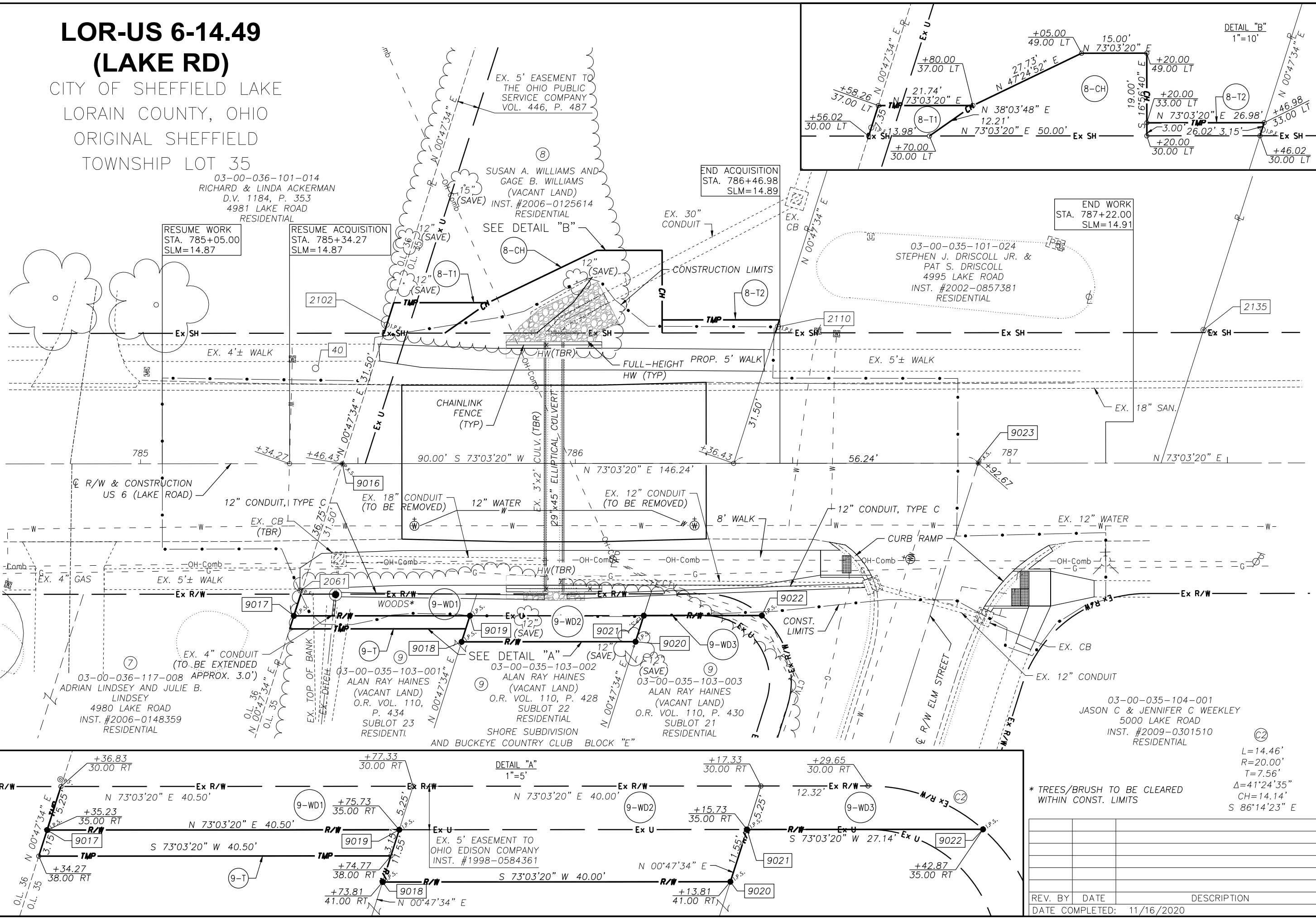

PID NO. 111579
R/W DESIGNER JTS
R/W REVIEWER AMK

RIGHT OF WAY DETAIL SHEET
STA. 785+00 TO STA. 787+00

LOR-US 6-14.49
(LAKE RD)

7/7
31
31

* TREES/BRUSH TO BE CLEARED WITHIN CONST. LIMITS

L=14.46'
R=20.00'
T=7.56'
Δ=41°24'35"
CH=14.14'
S 86°14'23" E

REV. BY	DATE	DESCRIPTION

DATE COMPLETED: 11/16/2020