

Sandstone Post
Fd. & Used
S.W. Corner Lot No.
17

N00°39'42"E
899.03'
Rec & Act

Sandstone Post
Fd. & Used
7.96' West

76.2'

N01°03'10"E
465.00'

N00°32'15"E
2057.87'

3/4" Pipe Fd.
Fd. & Used
469.62'

PP 10-00-018-102-066
PP 10-00-018-102-020
Allen J. Grobe
Janet Babich
Doc. No. 2010-0335439

PP 10-00-018-102-036
John C. Roebuck Jr.
Linda L. Roebuck
Doc. No. 2000-0707180

266.00' Deed & Used
PP 10-00-017-000-033
Jeffrey D. Comrie
Doc. No. 1998-0574892

266.00' Deed & Used
PP 10-00-017-000-026
Thomas S. & Janice M. Mahl
Doc. No. 2000-0675395

266.00' Deed & Used
N00°32'15"E

LOT SPLIT & CONSOLIDATION

MADE AT THE INSTANCE OF
PETER MAROZSAN
KNOWN AS BEING PART OF ORIGINAL CARLISLE TWP. SEC. No. 17
LORAIN COUNTY, OHIO

I HEREBY STATE THAT THIS PLAT IS A TRUE AND ACCURATE REPRESENTATION OF THE PREMISES SHOWN HEREON, AND WAS BASED ON AN ACTUAL SURVEY PERFORMED ON THE GROUND UNDER MY SUPERVISION, AND IS IN ACCORDANCE WITH THE MINIMUM STANDARDS FOR BOUNDARY SURVEYS AS ADOPTED BY THE STATE OF OHIO, CHAPTER 4733-37 OF THE OHIO ADMINISTRATIVE CODE. ALL TO THE BEST OF MY KNOWLEDGE, INFORMATION AND PERSONAL BELIEFS. DISTANCES ARE GIVEN IN FEET AND DECIMAL PARTS THEREOF. COURSES ARE GIVEN TO AN ASSUMED MERIDIAN AND ARE USED TO INDICATE ANGLES ONLY.

HOFMANN-METZKER, INC.
REGISTERED PROFESSIONAL SURVEYORS
24 BEECH ST. - P.O. BOX 343
BEREA, OHIO 44017
(440) 234-7350 FAX (440) 234-7351
EMAIL: george_hm@hmftech.net



ACCEPTANCE

(WE) THE UNDERSIGNED OWNER(S) OF THE LAND SHOWN ON THIS MAP AND DESIGNATED AS PARCEL # 10-00-017-000-040 AND 10-00-017-000-019, DO HEREBY ACCEPT THIS LOT SPLIT AND CONSOLIDATION, AS SHOWN HEREON.

OWNER	OWNER
OWNER	OWNER

NOTARY

CLYDEMAN COUNTY
STATE OF OHIO
S.S. BEFORE ME A NOTARY PUBLIC IN AND FOR SAID COUNTY AND STATE DID PERSONALLY APPEAR THE ABOVE SIGNED WHO DID ACKNOWLEDGE THE SIGNING OF THE FOREGOING INSTRUMENT TO BE HIS/HER/THEIR" FREE ACT AND DEED, IN TESTIMONY WHEREOF I HAVE HEREUNTO SET MY HAND AND OFFICIAL SEAL AT _____, OHIO THIS ____ DAY OF _____, 201__.

Notary Public

PP 10-00-017-000-011
Kenneth Diedrick
O.R. 76, P. 66

REFERENCES

- Carrington Pointe Estates Subdivision
- Survey by John Poznyak Dated Jan. 8, 1990
- Survey for Raintree Development Group by Rodger Simon Dated Feb. 1999
- TITLE DEED AND ADJOINERS DEEDS

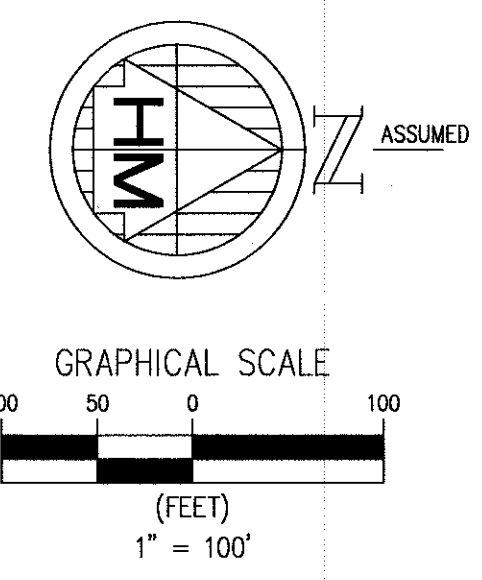

BASIS OF BEARINGS
EXISTING CENTERLINE OF SLIFE ROAD
IN SECTION 17 BEARING
N 89° 50' 00"E

PARCEL "A"
85.0149 ACRES

PP 10-00-017-000-040
Yolanda Lottman, Tr.
Deed Vol. 245, P. 1862

SURVEY LEGEND

- calc Denotes Calculated Distance or Angle
- prev Denotes Previous Distance or Angle
- state Denotes State Distance or Angle
- obs Denotes Observed Distance or Angle
- r Denotes Record Distance or Angle
- d Denotes Deed Distance or Angle
- u Denotes Used Point, Distance or Angle
- R/W Denotes Right of Way
- C Denotes Centerline
- P Denotes Property Line
- B Denotes Baseline
- I.P.S. Denotes 5/8" Iron Pin 30" Long Set and Capped 6752/7477
- Denotes Iron Pipe Found
- Denotes Iron Pin Found
- Denotes Existing Iron Pin Monument Found
- × Denotes Drill Hole Found or Set
- ⊙ Denotes Nail Found or Set
- Denotes Hub Stake Found or Set

PARCEL "C"
2.0008 ACRES

PARCEL "B"
2.4442 ACRES

SLIFE ROAD 60'