

NORTH

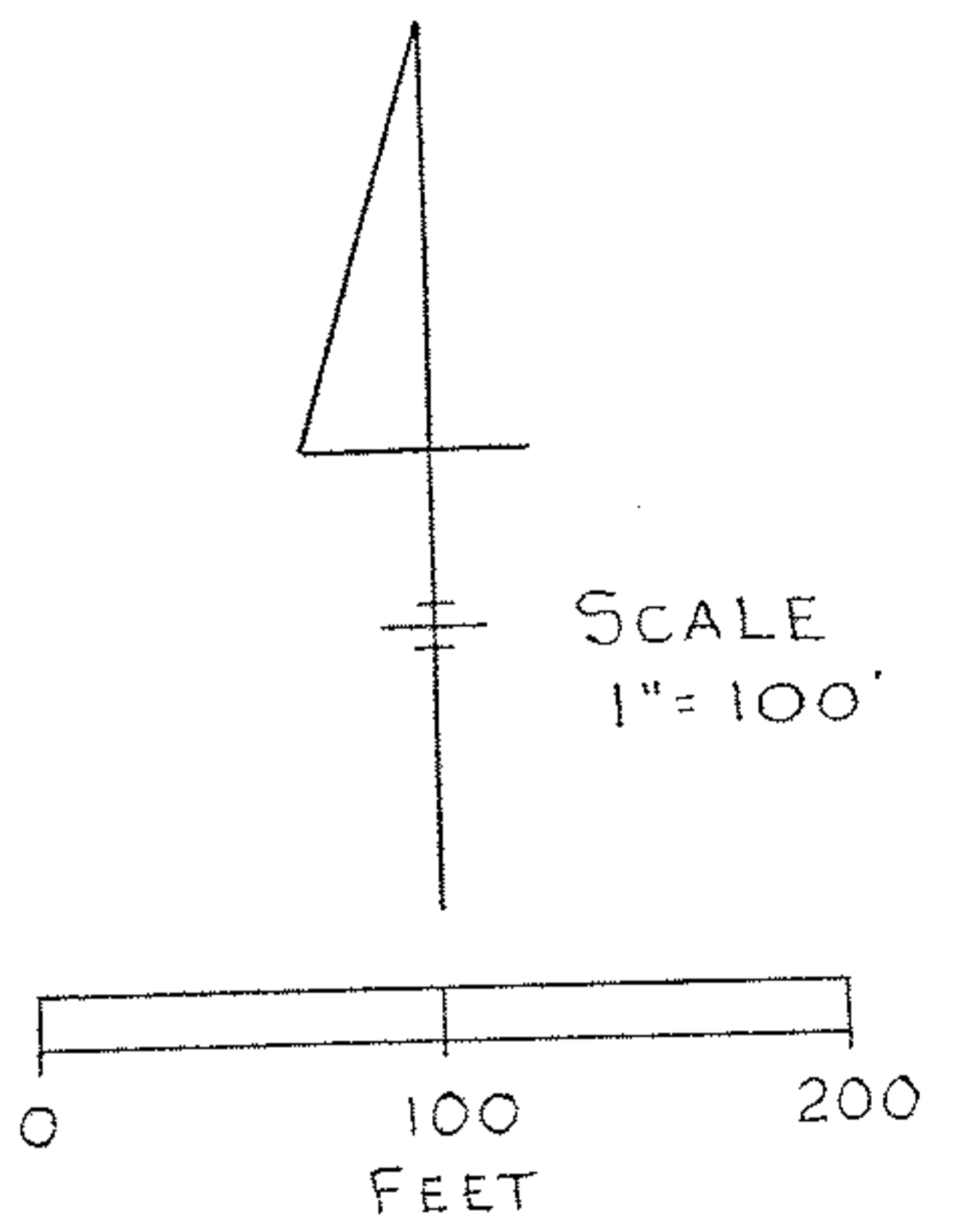

LEGEND:
 Iron Pipes or Rods Found: \circ
 $\frac{1}{2}$ " Iron Rods Set: \circ

02814
 APPROVED
 LORAIN CO.
 MAP DEPT
 DATE 3-22-10
 115-00-104-000-015
 PAGE 8-D
 BY JHAFIELD
 #10-02814

#44759

Charles P. Waryu 9/21/2009
 CHARLES P. WARYU
 Registered Surveyor No. 5029

SPLITS COMBINED
 PARCEL "A" 1.4305 Ac. — 2.4305 Ac.
 PARCEL "B" 18.0977 Ac. — 20.4183 Ac.

MAP OF SURVEY MADE
 Part of Original Henrietta
 Township Lot No. 104
 Lorain County, Ohio
 For David W. Swiers Sr.
 September 2009

Perm. Par. No. 05-00-104-000-002, 003, 015, 016