

PLAT OF BOUNDARY SURVEY

GILL INVESTMENTS, LLC

PART OF ORIGINAL LOT 34, EAST OF BLACK RIVER, TOWNSHIP OF ELYRIA

CITY OF ELYRIA, LORAIN COUNTY, OHIO

Legend

- ⊕ 1/2" Iron Pin Found
- Iron Pipe Found
- Drillhole Found

<b>P.P. NO.</b> 06-25-034-104-025	
<b>SPLIT #</b> #04-01043-A	<b>SURVEY</b> July 2004
<b>MAP PAGE</b> 6-104	
<b>SURVEYOR</b> Alex Kelsner	

APPROVED LORAIN CO. MAP DEPT
DATE 8-24-04
PAGE 6-104
BY D. Holland #04-01043-A

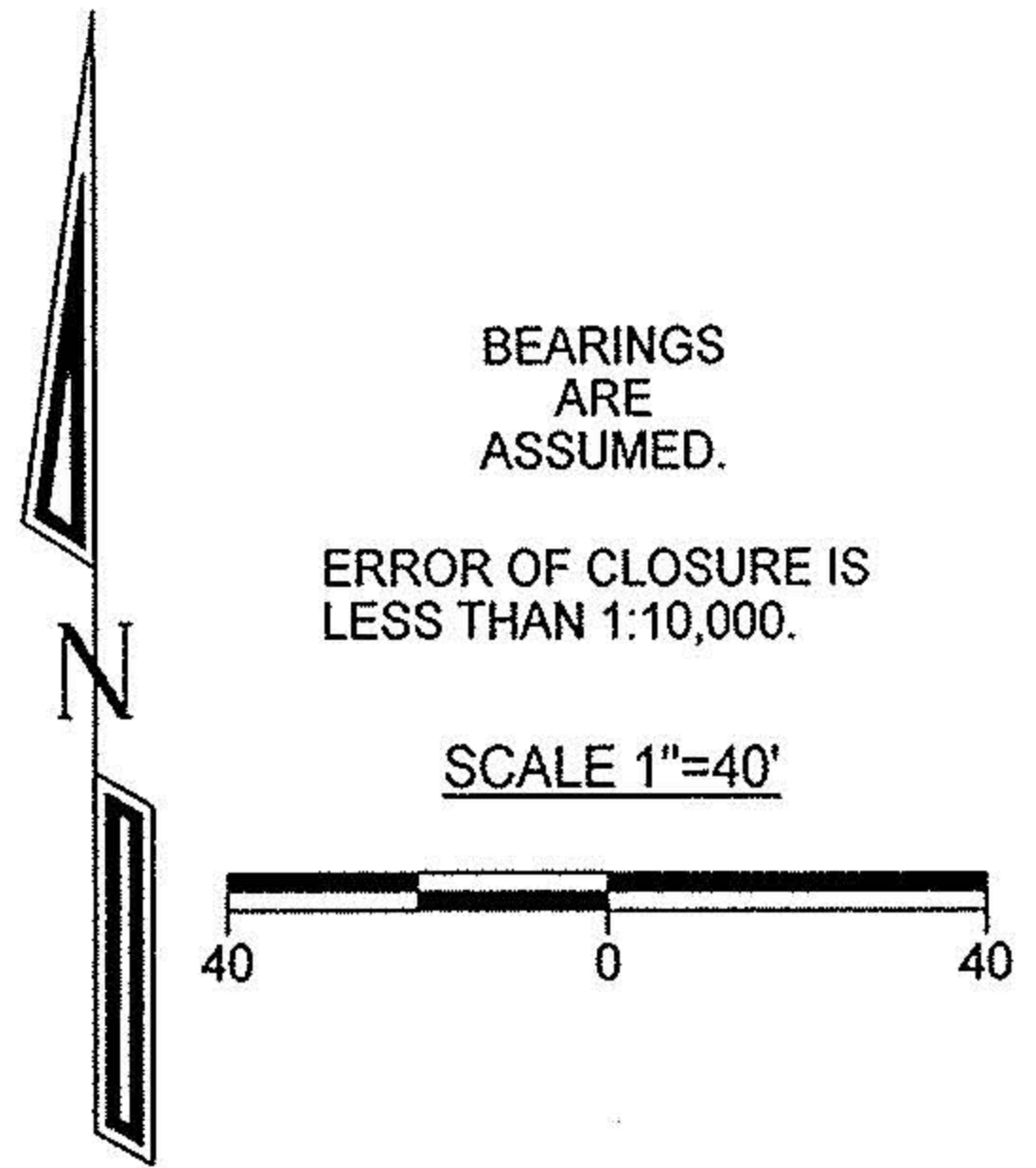
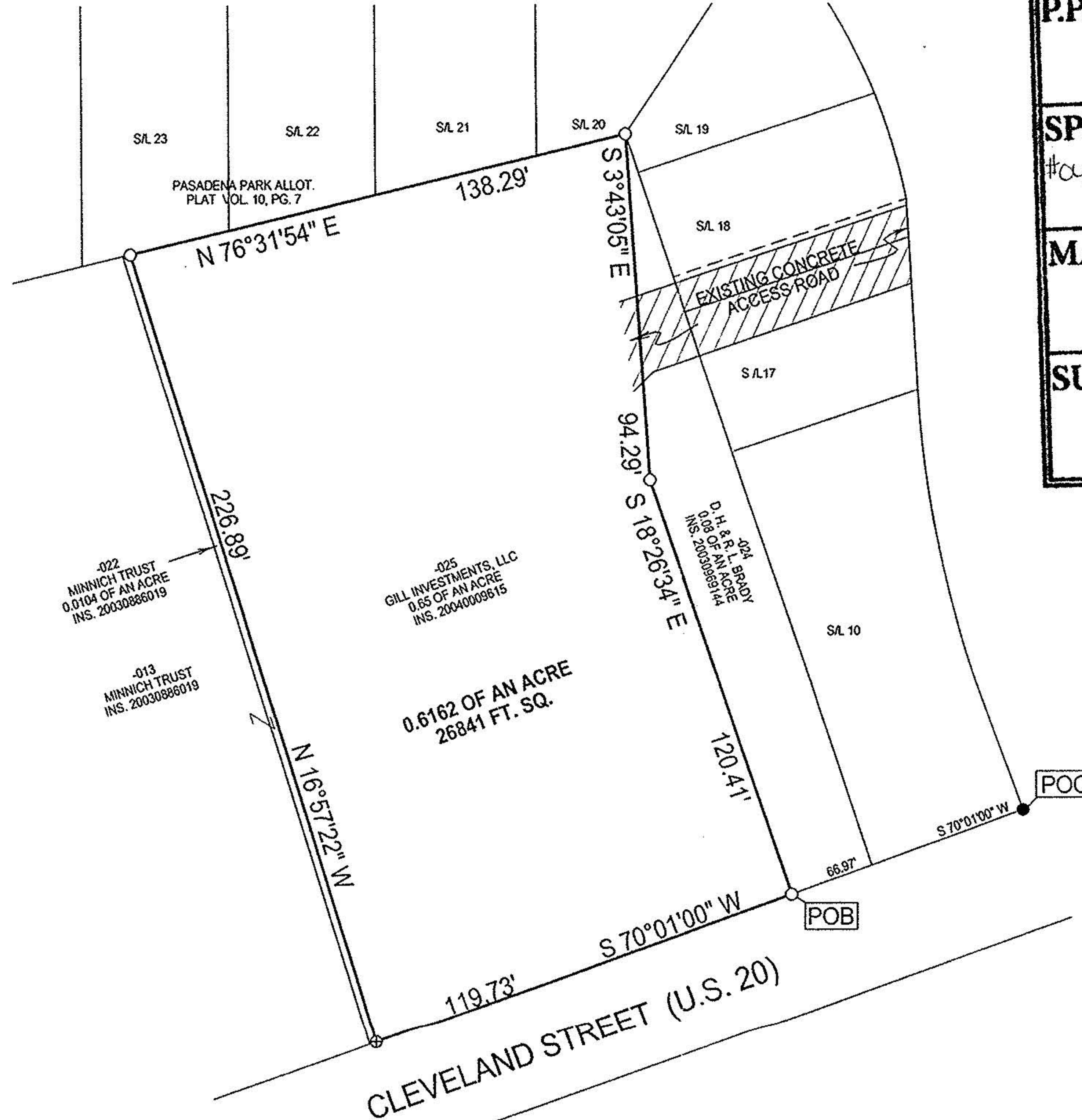

LAUNDON • SIMON • KELSNER & ASSOC., INC.  
 PROFESSIONAL LAND SURVEYORS  
 110 MIDDLE AVE. • ELYRIA, OHIO • 44035  
 PHONE (440) 322-7625  
 Alex Kelsner RLS #7871

DATE:	7/28/04
JOB NO.:	04-3735