

ESTATES OF SHEFFIELD EAST SUBDIVISION

SITUATED IN THE VILLAGE OF SHEFFIELD, COUNTY OF LORAIN, STATE OF OHIO AND KNOWN AS BEING PART OF THE ORIGINAL SHEFFIELD TOWNSHIP LOT NUMBERS 7 AND 8

OWNER'S CERTIFICATE

SITUATED IN THE VILLAGE OF SHEFFIELD, COUNTY OF LORAIN, STATE OF OHIO, KNOWN AS BEING A PART OF ORIGINAL SHEFFIELD TOWNSHIP LOT NUMBERS 7 AND 8 AND BEING PARCEL NUMBER 2 AND PARCEL NUMBER 4 DESCRIBED IN A DEED TO HARRY R. GERENT, ET AL AS RECORDED IN DOCUMENT #20030919614 OF THE LORAIN COUNTY DEED RECORDS CONTAINING 28.5546 ACRES OF LAND.

THE UNDERSIGNED HARRY R. GERENT HEREBY CERTIFIES THAT THE ATTACHED PLAT ACCURATELY REPRESENTS THE "ESTATES OF SHEFFIELD EAST SUBDIVISION", A SUBDIVISION OF LOTS 1 THRU 36 AND BLOCKS "A", "B", "C" & "D" INCLUSIVE; DOES HEREBY ACKNOWLEDGE THIS PLAT OF SAME AND DEDICATE TO PUBLIC USE AS SUCH, ALL OR PARTS OF THE ROADS, BOULEVARDS, CUL-DE-SACS, SHOWN HEREIN AND HERETOFORE NOT DEDICATED.

THE UNDERSIGNED FURTHER AGREES THAT ANY USE OF IMPROVEMENTS MADE ON THIS LAND SHALL BE IN CONFORMITY WITH ALL EXISTING PLATTING, ZONING, HEALTH OR OTHER LAWFUL RULES OR REGULATIONS INCLUDING THE APPLICABLE OFF-STREET LOADING AND PARKING REQUIREMENTS OF THE VILLAGE OF SHEFFIELD FOR THE BENEFIT OF HIMSELF AND ALL OTHER SUBSEQUENT PARTIES TAKING TITLE FROM, UNDER OR THROUGH THE UNDERSIGNED.

THE DIMENSIONS OF THE LOTS AND STREETS ARE SHOWN ON THE PLAT IN FEET AND DECIMAL PARTS THEREOF. EASEMENTS ARE RESERVED WHERE INDICATED ON THE PLAT IN FEET AND DECIMAL PARTS THEREOF. EASEMENTS ARE RESERVED WHERE INDICATED ON THE PLAT FOR PUBLIC UTILITY PURPOSES ABOVE AND BENEATH THE SURFACE OF THE GROUND.

IN WITNESS THEREOF THE UNDERSIGNED HAVE HEREUNTO SET THEIR HANDS THIS 7th DAY OF September, 2005.

WITNESS Denise Kavanagh BY: Harry R. Gerent
HARRY R. GERENT

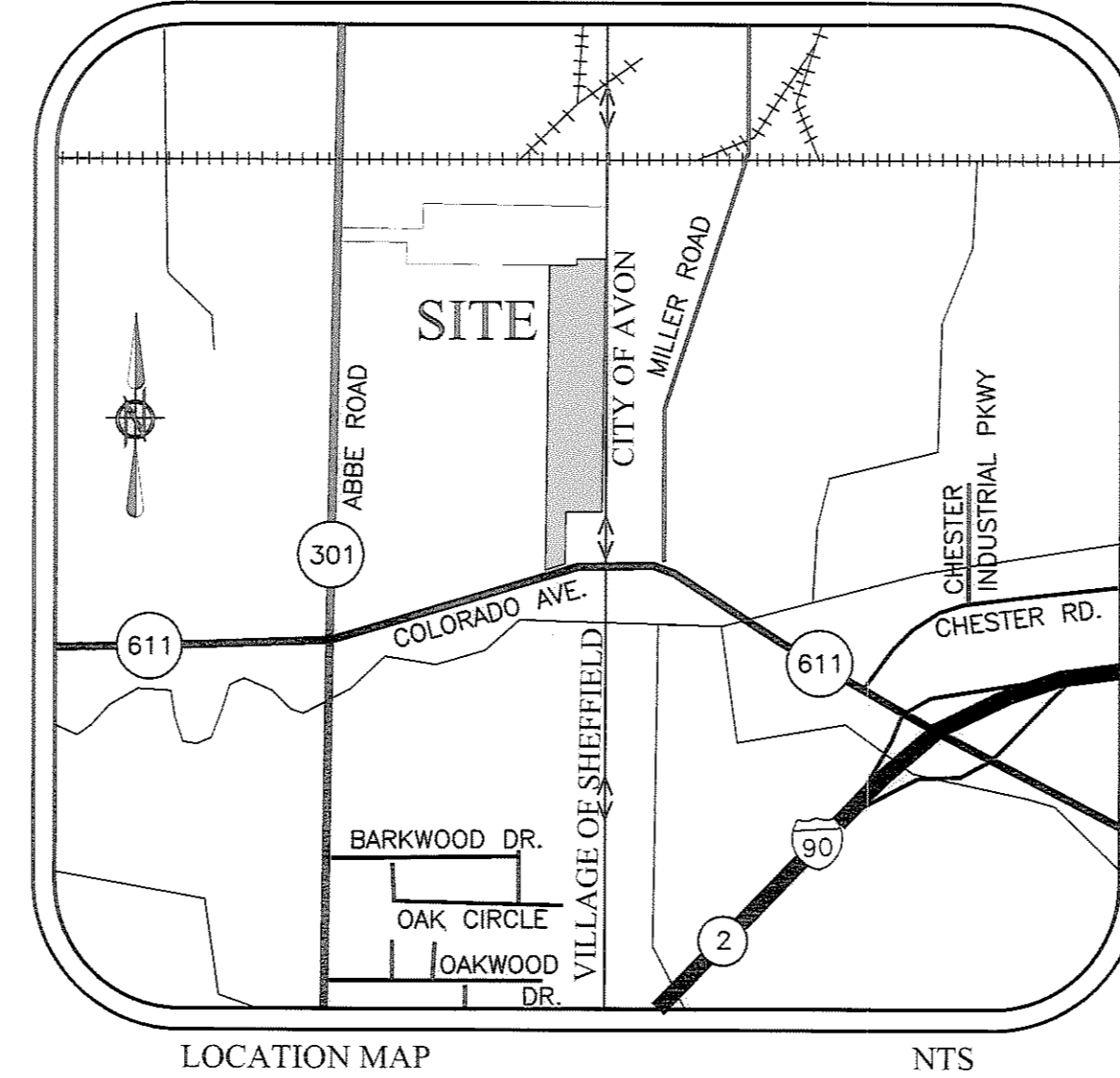

SHEFFIELD VILLAGE ENGINEER:
THIS PLAT IS HEREBY APPROVED, THIS 7th DAY OF September, 2005.

Christopher L. Howard
CHRISTOPHER L. HOWARD, P.E.

PLANNING COMMISSION:
THIS PLAT IS HEREBY APPROVED BY THE PLANNING COMMISSION OF THE VILLAGE OF SHEFFIELD, OHIO, THIS 7th DAY OF September, 2005.

Chairman
CHAIRMAN

VILLAGE SOLICITOR:
THIS PLAT OF "ESTATES OF SHEFFIELD EAST SUBDIVISION" IS COVERED BY A PROPER CERTIFICATE OF TITLE AND THE DEDICATION IS HEREBY APPROVED AS TO FORM.

Luke McConville
LUKE MCCONVILLE

VILLAGE ADMINISTRATOR:
THIS PLAT IS HEREBY APPROVED, THIS 7th DAY OF September, 2005.

Ken Kaczay
KEN KACZAY

VILLAGE COUNCIL:
THIS IS TO CERTIFY THAT THIS PLAT OF "ESTATES OF SHEFFIELD EAST SUBDIVISION" IS HEREBY DEDICATED FOR THE STREET PURPOSES AS SHOWN HEREON AND IS ACCEPTED THIS 7th DAY OF September, 2005.

Mayor Darlene Ondercin
MAYOR DARLENE ONDERCIN

TIM PELCIC, CLERK OF COUNCIL

NO TRANSFER NECESSARY
MARK R. STEWART
LORAIN COUNTY AUDITOR,
Tam Anderson 9/25/2005
DEPUTY

RECORDED
SEP 19 2005
LORAIN COUNTY AUDITOR

SEP 19 2005
RECEIVED FOR RECORD
at 2:07 P.M. in PLAT RECORD
VOL. 86 JUDITH M. NEDWICK
PAGES Lorain County Recorder
57, 60, 61 and 62 inc
BOXLETS 345 60 MR
(LAURA)
LORAIN COUNTY RECORDER

SURVEYOR'S CERTIFICATE

THIS IS TO CERTIFY THAT, AT THE REQUEST OF THE OWNERS, I HAVE PREPARED THIS PLAT AS SHOWN HEREON SITUATED IN THE VILLAGE OF SHEFFIELD, COUNTY OF LORAIN, STATE OF OHIO, KNOWN AS BEING PART OF THE ORIGINAL SHEFFIELD TOWNSHIP LOT NUMBERS 7 AND 8 AS DESCRIBED IN A DEED TO HARRY R. GERENT, ET AL AS RECORDED IN DOCUMENT #20030919614 (PARCEL NUMBER 2 AND PARCEL NUMBER 4) OF THE LORAIN COUNTY DEED RECORDS AND CONTAINING WITHIN SAID BOUNDS 28.5546 ACRES OF LAND; OF WHICH 27.9184 ACRES ARE LOCATED IN ORIGINAL LOT NUMBER 8, AND 0.6362 ACRES ARE LOCATED IN ORIGINAL LOT NUMBER 7, BE THE SAME MORE OR LESS, BUT SUBJECT TO ALL LEGAL HIGHWAYS AND EASEMENTS. AT ALL POINTS THUSLY INDICATED ○ IRON PIN MONUMENTS WERE FOUND AND AT ALL POINTS THUSLY INDICATED ● IRON PIN MONUMENTS WERE SET. DISTANCES ARE SHOWN IN FEET AND DECIMAL PARTS THEREOF. BEARINGS SHOWN ARE ASSUMED AND USED TO DESCRIBE ANGLES ONLY. THE PLAN REPRESENTS A SURVEY FOR WHICH A TRAVERSE OF THE EXTERIOR BOUNDARIES OF THE TRACT AND EACH BLOCK COMPUTED FROM FIELD MEASUREMENTS OF THE TRACT CLOSED WITHIN A LIMIT OF ERROR OF ONE (1) FOOT TO TEN THOUSAND (10,000) FEET OF THE PERIMETER BEFORE BALANCING THE SURVEY. ALL OF WHICH I CERTIFY TO BE CORRECT.

Christopher M. Hitzel
CHRISTOPHER M. HIRZEL, P.S.
REGISTERED SURVEYOR NO. 8081
DATE 09/06/2005

ACREAGE SUMMARY
3.9585 ACRES IN RIGHT-OF-WAY
11.5266 ACRES IN BLOCKS "A", "B", "C" & "D"
13.0695 ACRES IN SUBLOTS 1-36
28.5546 ACRES TOTAL IN PHASE I

BY: Johanna Mueller, Trustee
JOHANNA MUELLER, TRUSTEE

BY: Christine Klann by Harry R. Gerent P.S.
CHRISTINE KLANN

Miselle L. Williamson
Notary Public for State of Ohio

NOTARY PUBLIC:

STATE OF OHIO
COUNTY OF Lorain
BEFORE ME, A NOTARY PUBLIC, IN AND FOR SAID COUNTY AND STATE, DID PERSONALLY APPEAR HARRY R. GERENT, WHO ACKNOWLEDGED THE SIGNING OF THIS PLAT TO BE HIS OWN FREE ACT AND DEED FOR THE PURPOSES THEREIN EXPRESSED. IN WITNESS THEREOF I HAVE HEREUNTO SET MY HAND AND OFFICIAL SEAL THIS 7th DAY OF September, 2005.

Mary J. Bramhall
NOTARY PUBLIC
MARY J. BRAMHALL, NOTARY PUBLIC
STATE OF OHIO
MY COMMISSION EXPIRES: MY COMMISSION EXPIRES SEPT 3, 2007

OWNER'S CERTIFICATE

THE UNDERSIGNED, JOHN & JOHANNA MUELLER, TRUSTEES, HERMANN & CHRISTINE KLANN, HEREBY CERTIFIES THAT THE ATTACHED PLAT ACCURATELY REPRESENTS THE "ESTATES OF SHEFFIELD EAST SUBDIVISION", A SUBDIVISION OF LOTS 1 THRU 36 AND BLOCKS "A", "B", "C" & "D" INCLUSIVE; DOES HEREBY ACKNOWLEDGE THIS PLAT OF SAME AND DEDICATE TO PUBLIC USE AS SUCH, ALL OR PARTS OF THE ROADS, BOULEVARDS, CUL-DE-SACS, SHOWN HEREIN AND HERETOFORE NOT DEDICATED.

THE UNDERSIGNED FURTHER AGREES THAT ANY USE OF IMPROVEMENTS MADE ON THIS LAND SHALL BE IN CONFORMITY WITH ALL EXISTING PLATTING, ZONING, HEALTH OR OTHER LAWFUL RULES OR REGULATIONS INCLUDING THE APPLICABLE OFF-STREET LOADING AND PARKING REQUIREMENTS OF THE VILLAGE OF SHEFFIELD FOR THE BENEFIT OF HIMSELF AND ALL OTHER SUBSEQUENT PARTIES TAKING TITLE FROM, UNDER OR THROUGH THE UNDERSIGNED.

THE DIMENSIONS OF THE LOTS AND STREETS ARE SHOWN ON THE PLAT IN FEET AND DECIMAL PARTS THEREOF. EASEMENTS ARE RESERVED WHERE INDICATED ON THE PLAT IN FEET AND DECIMAL PARTS THEREOF. EASEMENTS ARE RESERVED WHERE INDICATED ON THE PLAT FOR PUBLIC UTILITY PURPOSES ABOVE AND BENEATH THE SURFACE OF THE GROUND.

IN WITNESS THEREOF THE UNDERSIGNED HAVE HEREUNTO SET THEIR HANDS THIS 20th DAY OF Sept, 2005.

WITNESS Miselle L. Williamson BY: John Mueller, Trustee
JOHN MUELLER, TRUSTEE

WITNESS Ken W. Handberg BY: Hermann Klann by Harry R. Gerent P.S.
HERMANN KLANN

J:\02-1193\DRAWINGS\DWG\PLAT.dwg [TITLE]

DATE	BY:	DESCRIPTION:
08/09/2004	CMH	ISSUED FOR REVIEW
12/29/2004	CMH	UPDATE PER COUNTY COMMENTS
09/06/2005	CMH	ISSUED FOR SIGNATURES

CHECKED BY: CMH

BRAMHALL
ENGINEERING AND SURVEYING CO., INC.
37307 HARVEST DRIVE AVON, OHIO 44011
(440) 934 - 7878 (440) 934 - 7879 FAX

PREPARED FOR:
HARRY R. GERENT
3470 ABBE ROAD
SHEFFIELD VILLAGE, OHIO 44054
(440) 934-3556

Re-record for owner signatures
ESTATES OF SHEFFIELD EAST SUBDIVISION
TITLE SHEET
VILLAGE OF SHEFFIELD, COUNTY OF LORAIN,
STATE OF OHIO

SHEET
1 OF 4
JOB NO.
02-1193

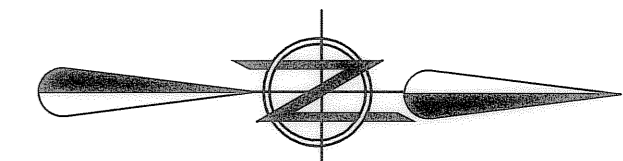

GRAPHIC SCALE

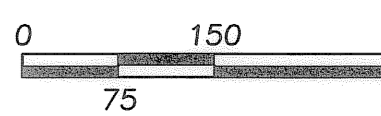

(IN FEET)

SCALE: 1" = 150'

LEGEND

- CENTERLINE OF RIGHT-OF-WAY
- IRON PIPE OR PIN FOUND AS INDICATED
- 5/8" REBAR W/CAP STAMPED "BRAMHALL 8073" SET
- (M.) (MEAS.) MEASURED
- (R.) (REC.) RECORD
- (CALC.) CALCULATED
- RIGHT-OF-WAY LINE
- MONUMENT BOX FOUND AS INDICATED
- MONUMENT BOX SET
- O.L. LINE
- ZONING LINE

CURVE TABLE

CURVE	LENGTH	RADIUS	CHORD	BEARING	TANGENT	DELTA
C5	23.43	259.55	23.42	N16°05'09"W	11.72	5°10'22"
C8	114.00	290.00	113.27	S11°14'09"W	57.75	22°31'23"
C9	198.47	290.00	194.62	N02°53'28"E	103.30	39°12'45"
C13	10.33	320.14	10.33	N14°15'31"W	5.17	1°50'58"
C20	106.04	320.00	105.56	S09°23'17"W	53.51	18°59'11"
C21	85.83	260.00	85.44	N09°29'05"E	43.31	18°54'51"
C28	103.35	2943.46	103.34	S72°37'25"W	51.68	2°00'42"
C29	96.65	2943.46	96.64	S74°34'12"W	48.33	1°52'53"
C30	128.82	10342.71	128.82	N01°34'20"E	64.41	0°42'49"
C31	12.12	470.00	12.12	N09°46'51"W	6.06	1°28'38"

LINE TABLE

LINE	LENGTH	BEARING
L1	17.89	S46°53'36"E
L2	31.42	N89°15'15"E
L3	31.09	N89°15'15"E
L4	80.27	S87°02'48"W
L5	1.49	S02°26'29"E
L6	44.66	S89°15'15"W

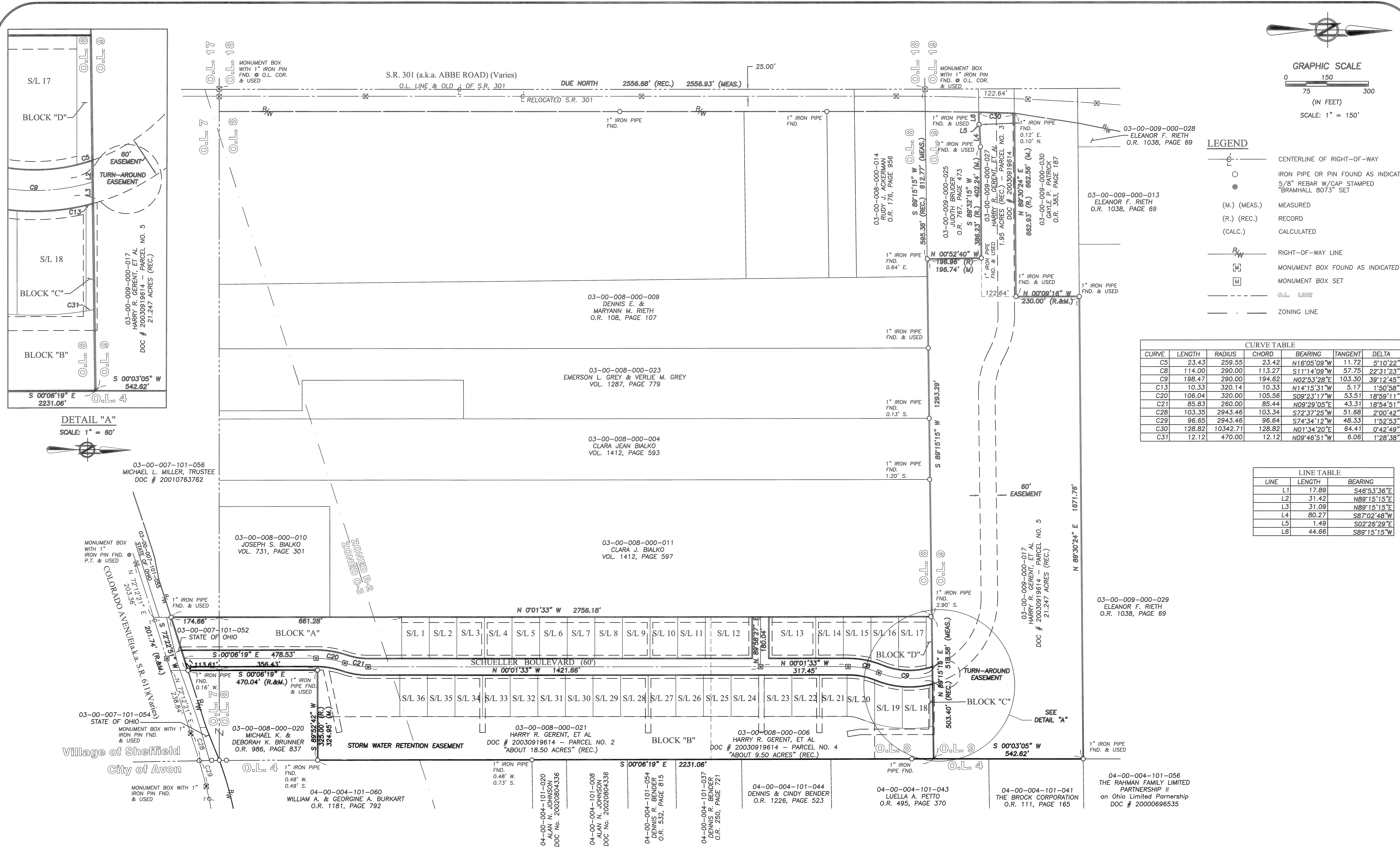

DETAIL "A"

SCALE: 1" = 60'



E:\02-1193\DRAWINGS\DWG\PLAT.dwg (OVERALL)

DATE	BY	DESCRIPTION
08/09/2004	CMH	ISSUED FOR REVIEW
12/29/2004	CMH	UPDATE PER COUNTY COMMENTS
09/06/2005	CMH	ISSUED FOR SIGNATURES

DRAWN BY:
BMM

CHECKED BY:
CLH

BRAMHALL
ENGINEERING AND SURVEYING CO., INC.
37307 HARVEST DRIVE AVON, OHIO 44011
(440) 934 - 7878 (440) 934 - 7879 FAX

PREPARED FOR:
HARRY R. GERENT
3470 ABBE ROAD
SHEFFIELD VILLAGE, OHIO 44054
(440) 934-3556

ESTATES OF SHEFFIELD EAST SUBDIVISION
RECORD PLAT
VILLAGE OF SHEFFIELD, COUNTY OF LORAIN, STATE OF OHIO

SHEET
2 OF 4
JOB NO.
02-1193

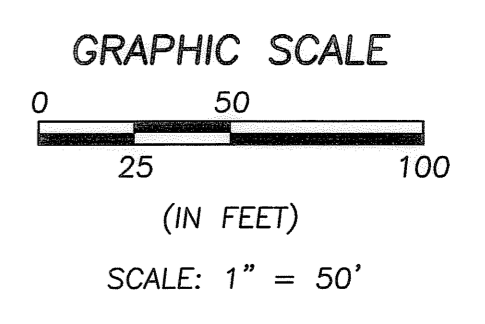
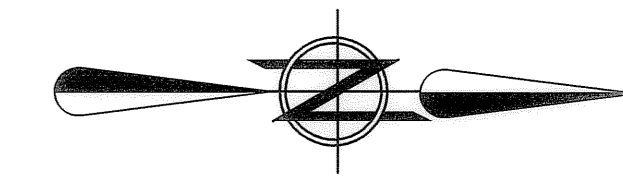

LEGEND

- IRON PIN/PIPE FOUND AS INDICATED
- 5/8" REBAR SET WITH CAP STAMPED "BRAMHALL"
- ☐ MONUMENT BOX FOUND
- ▣ MONUMENT BOX SET

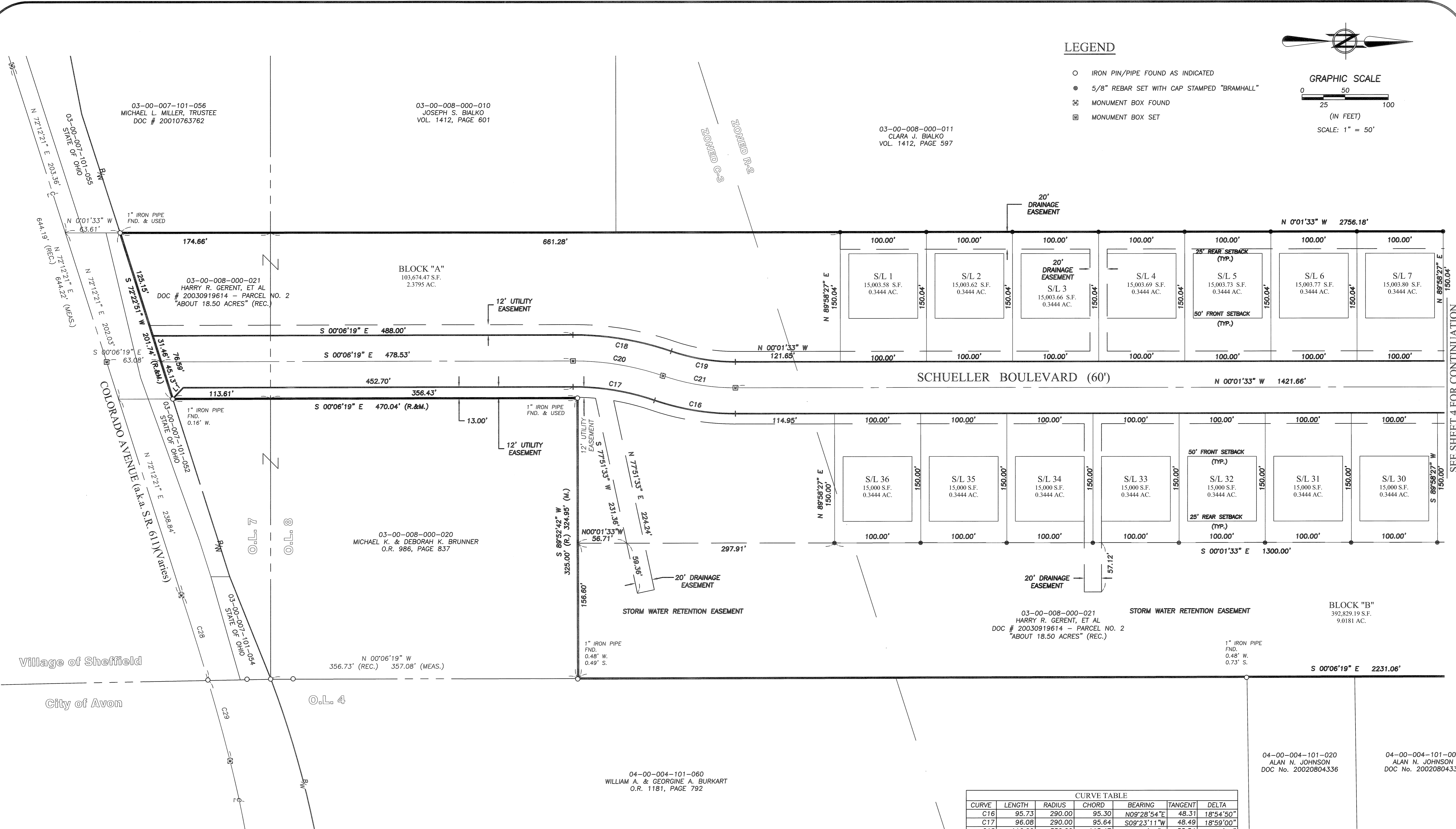

SEE SHEET 4 FOR CONTINUATION

NOTE:
 DRILL HOLES TO BE SET IN CONCRETE CURB AT THE EXTENSION OF ALL SUBLOT PROPERTY LINES.

CURVE TABLE						
CURVE	LENGTH	RADIUS	CHORD	BEARING	TANGENT	DELTA
C16	95.73	290.00	95.30	N09°28'54"E	48.31	18°54'50"
C17	96.08	290.00	95.64	S09°23'11"W	48.49	18°59'00"
C18	116.00	350.00	115.47	S09°23'21"W	58.54	18°59'21"
C19	75.93	230.00	75.58	N09°29'17"E	38.31	18°54'53"
C20	106.04	320.00	105.56	S09°23'17"W	53.51	18°59'11"
C21	85.83	260.00	85.44	N09°29'05"E	43.31	18°54'51"
C28	103.35	2943.46	103.34	S72°37'25"W	51.68	2°00'42"
C29	96.65	2943.46	96.64	S74°34'12"W	48.33	1°52'53"

LINE TABLE		
LINE	LENGTH	BEARING
L1	17.89	S46°53'36"E

F:\02-1199-DRAWINGS\DWG\PLAT.dwg [CLOSE-UP]

DATE	BY	DESCRIPTION
08/09/2004	CMH	ISSUED FOR REVIEW
12/29/2004	CMH	UPDATE PER COUNTY COMMENTS
09/06/2005	CMH	ISSUED FOR SIGNATURES

DRAWN BY:
BMM

CHECKED BY:
CMH

BRAMHALL
 ENGINEERING AND SURVEYING CO., INC.
 37307 HARVEST DRIVE AVON, OHIO 44011
 (440) 934 - 7878 (440) 934 - 7879 FAX

PREPARED FOR:
HARRY R. GERENT
 3470 ABBE ROAD
 SHEFFIELD VILLAGE, OHIO 44054
 (440) 934-3556

ESTATES OF SHEFFIELD EAST SUBDIVISION
RECORD PLAT
 VILLAGE OF SHEFFIELD, COUNTY OF LORAIN, STATE OF OHIO

SHEET
 3 OF 4
 JOB NO.
 02-1193

03-00-008-000-011
CLARA J. BIALKO
VOL. 1412, PAGE 597

CURVE TABLE						
CURVE	LENGTH	RADIUS	CHORD	BEARING	TANGENT	DELTA
C1	83.49	320.00	83.26	S07°26'57"W	41.99	14°56'58"
C2	42.30	320.00	42.27	S18°42'38"W	21.18	7°34'25"
C3	62.43	259.07	62.28	N15°37'08"E	31.37	13°48'25"
C4	100.72	259.41	100.08	N02°22'48"W	51.00	22°14'42"
C5	23.43	259.55	23.42	N16°05'09"W	11.72	5°10'22"
C6	176.33	259.55	172.96	N03°03'06"E	91.72	38°55'31"
C7	125.79	320.00	124.98	S11°14'09"W	63.72	22°31'23"
C8	114.00	290.00	113.27	S11°14'09"W	57.75	22°31'23"
C9	198.47	290.00	194.62	N02°53'28"E	103.30	39°12'45"
C10	98.14	260.00	97.56	S10°47'18"W	49.66	21°37'40"
C11	99.42	320.00	99.02	N13°35'49"E	50.11	17°48'04"
C12	100.70	320.00	100.28	N04°19'06"W	50.77	18°01'46"
C13	10.33	320.00	10.33	N14°15'31"W	5.17	1°50'58"
C14	206.61	320.00	203.04	N04°00'03"E	107.05	36°59'36"
C15	102.21	260.00	101.55	S11°14'09"W	51.77	22°31'23"
C22	43.24	110.00	42.96	S11°14'09"W	21.90	22°31'23"
C23	56.84	470.00	56.81	N19°01'58"E	28.46	6°55'46"
C24	101.56	470.00	101.36	N09°22'40"E	50.98	12°22'51"
C25	100.32	470.00	100.13	N02°55'38"W	50.35	12°13'46"
C26	265.11	470.00	261.61	N06°20'18"E	136.19	32°19'06"
C27	4.06	260.00	4.06	S22°02'59"W	2.03	0°53'43"
C31	12.12	470.00	12.12	N09°46'51"W	6.06	1°28'38"

LINE TABLE		
LINE	LENGTH	BEARING
L2	31.42	N89°15'15"E
L3	31.09	N89°15'15"E

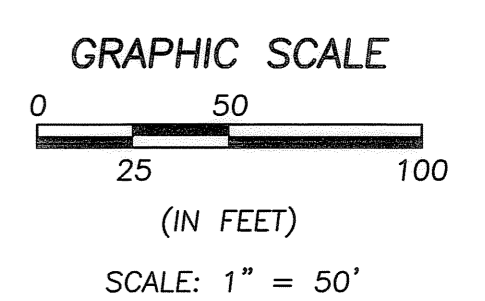
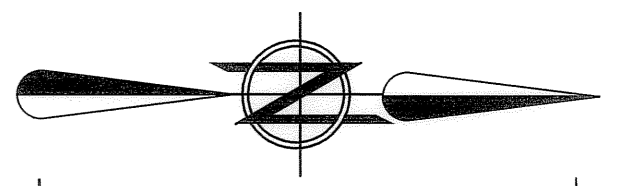

- LEGEND
- IRON PIN/PIPE FOUND AS INDICATED
 - 5/8" IRON REBAR WITH CAP STAMPED "BRAMHALL 8073" SET
 - ☐ MONUMENT BOX FOUND
 - ▣ MONUMENT BOX SET

03-00-009-000-017
HARRY R. GERENT, ET AL
DOC # 20030919614 - PARCEL NO. 5
21.247 ACRES (REC.)

1" IRON PIPE FND. & USED 2.90' S.

BLOCK "D"
3,938.60 S.F.
0.0904 AC.

BLOCK "C"
1,682.45 S.F.
0.0386 AC.

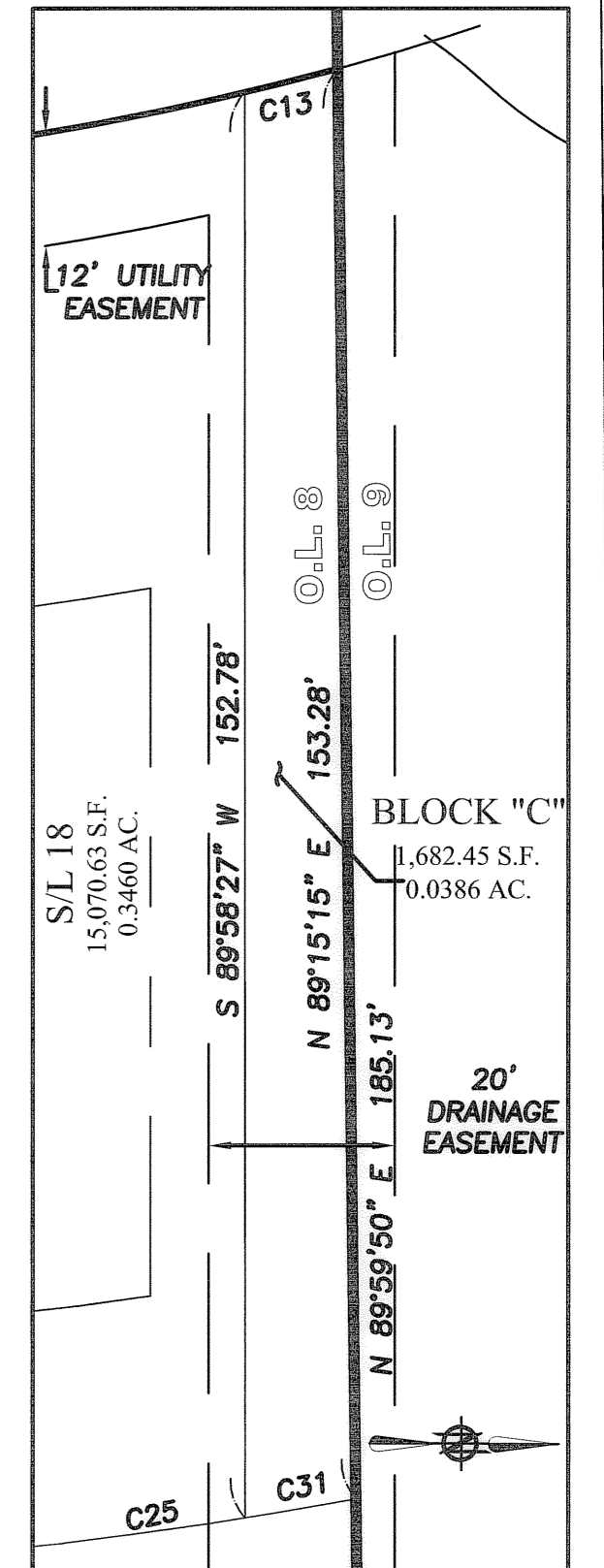

DETAIL "B"
SCALE: 1" = 20'

1" IRON PIPE FND. & USED

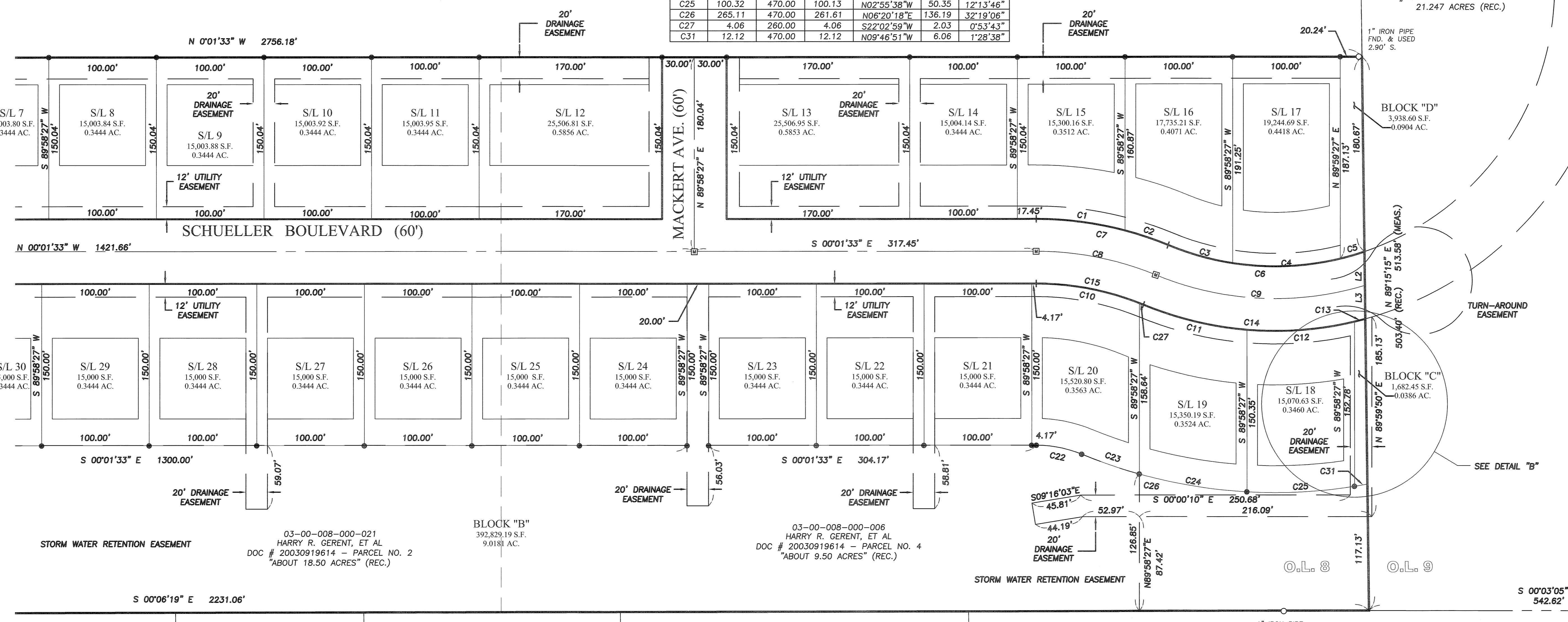

03-00-008-000-021
HARRY R. GERENT, ET AL
DOC # 20030919614 - PARCEL NO. 2
"ABOUT 18.50 ACRES" (REC.)

BLOCK "B"
392,829.19 S.F.
9.0181 AC.

03-00-008-000-006
HARRY R. GERENT, ET AL
DOC # 20030919614 - PARCEL NO. 4
"ABOUT 9.50 ACRES" (REC.)

04-00-004-101-008
ALAN N. JOHNSON
DOC No. 20020804336

04-00-004-101-054
DENNIS R. BENDER
O.R. 532, PAGE 815

04-00-004-101-037
DENNIS R. BENDER
O.R. 250, PAGE 721

04-00-004-101-044
DENNIS & CINDY BENDER
O.R. 1226, PAGE 523

04-00-004-101-043
LUELLA A. PETTO
O.R. 495, PAGE 370

04-00-004-101-041
THE BROCK CORPORATION
O.R. 111, PAGE 165

NOTE:
DRILL HOLES TO BE SET IN CONCRETE CURB AT THE EXTENSION OF ALL SUBLOT PROPERTY LINES.

L:\02-1193-DRAWINGS\DWG\PLAT.dwg [CLOSE-UP]

DATE	BY	DESCRIPTION
08/09/2004	CMH	ISSUED FOR REVIEW
12/29/2004	CMH	UPDATE PER COUNTY COMMENTS
09/06/2005	CMH	ISSUED FOR SIGNATURES

DRAWN BY: BMM

CHECKED BY: CMH

BRAMHALL
ENGINEERING AND SURVEYING CO., INC.
37307 HARVEST DRIVE AVON, OHIO 44011
(440) 934 - 7878 (440) 934 - 7879 FAX

PREPARED FOR:
HARRY R. GERENT
3470 ABBE ROAD
SHEFFIELD VILLAGE, OHIO 44054
(440) 934-3556

ESTATES OF SHEFFIELD EAST SUBDIVISION
RECORD PLAT
VILLAGE OF SHEFFIELD, COUNTY OF LORAIN, STATE OF OHIO

SHEET
4 OF 4
JOB NO.
02-1193