

- LEGEND**
- ⊞ EXISTING MONUMENT BOX
 - ⊙ IRON PIPE/ IRON PIN/
5/8" KS CAPPED PIN FOUND
 - 5/8"x30" KS CAPPED PIN SET
 - ⊞ MONUMENT BOX

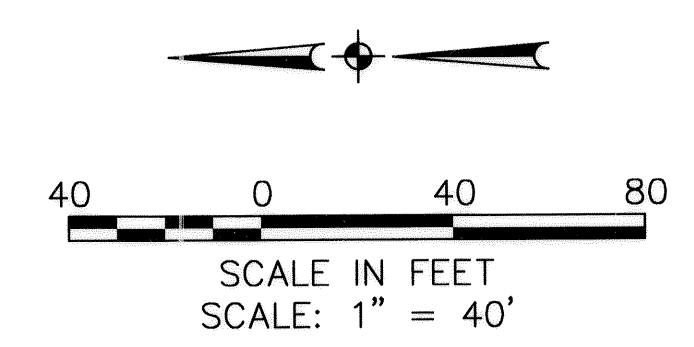

SUBLOT AREA - SQUARE FEET

SUBLOT	SQUARE FEET	SUBLOT	SQUARE FEET
1	1,864	22	1,864
2	1,670	23	1,864
3	1,670	24	1,670
4	1,864	25	1,485
5	1,864	26	1,668
6	1,668	27	1,864
7	1,668	28	1,864
8	1,864	29	1,668
9	1,864	30	1,485
10	1,668	31	1,668
11	1,485	32	1,864
12	1,668	33	1,864
13	1,864	34	1,668
14	1,864	35	1,485
15	1,668	36	1,668
16	1,485	37	1,864
17	1,668	38	1,864
18	1,864	39	1,668
19	1,864	40	1,485
20	1,668	41	1,668
21	1,668	42	1,864

CURVE TABLE

CURVE	LENGTH	RADIUS	TANGENT	DELTA	CHORD	BEARING
C1	34.76	90.00	17.60	22°07'49"	34.55	S11°00'27"E
C2	34.76	90.00	17.60	22°07'49"	34.55	N11°00'27"W
C3	99.58	160.00	51.46	35°39'33"	97.98	S17°46'19"E
C4	23.17	60.00	11.73	22°07'49"	23.03	S11°00'27"E
C5	46.35	120.00	23.47	22°07'49"	46.06	N11°00'27"W
C6	54.95	50.00	30.62	62°57'51"	52.22	S31°25'29"E
C7	254.43	60.00	97.98	242°57'51"	102.34	N58°34'31"E
C8	23.17	60.00	11.73	22°07'49"	23.03	N11°00'27"W
C9	46.35	120.00	23.47	22°07'49"	46.06	S11°00'27"E
C10	39.27	25.00	25.00	90°00'00"	35.36	S45°03'27"W
C11	39.27	25.00	25.00	89°54'34"	35.36	N44°56'20"W
C12	20.09	120.00	10.07	9°35'39"	20.07	S04°44'22"E
C13	20.39	60.00	10.29	19°28'16"	20.29	S09°40'41"E

A=239.28'
R=1000.00'
T=120.21'
Δ=12°42'35"
C=238.71'
CH=N 83°05'15" W

A=43.40'
R=1030.00'
T=21.70'
Δ=2°24'50"
C=43.39'
CH=N 88°44'08" W

A=40.87'
R=970.00'
T=20.44'
Δ=2°24'50"
C=40.86'
CH=N 88°44'08" W

02-02-011-000-099
LORAIN LAND DEVELOPMENT, LLC
#20030918760

SEE TABLE FOR AREA OF SUBLOTS
ALL LOT DIMENSIONS HAVE BEARINGS OF N89°56'33"W OR N0°03'27"E

BY	
DATE	
DESCRIPTION	
DATE: 01-26-04	DRAWN BY: BAP
REVISIONS	CH'D BY:
02-05-04	DWG.: 1-PLAT02
PER CITY COMMENTS	PATH: 02284-CS/
ORIGINAL ISSUE	F.B. LITD.

KS ASSOCIATES, INC.
960 Burns Road, Suite 100
Elyria, Ohio 44035
Phone (440) 365-4730
Fax (440) 365-4790
mailroom@ksassoc.com
www.ksassoc.com

RECORD PLAT
THE MEADOWS AT MARTIN'S RUN SUBDIVISION NO. 1
OF PART OF
BLACK RIVER TOWNSHIP ORIGINAL LOT NO. 11, TRACT 2
CITY OF LORAIN COUNTY OF LORAIN STATE OF OHIO

SHEET 2	OF 2
JOB NO. 02284-CS	