

JOHN & JOHANNA MUELLER  
O.R. 1135, PG. 331

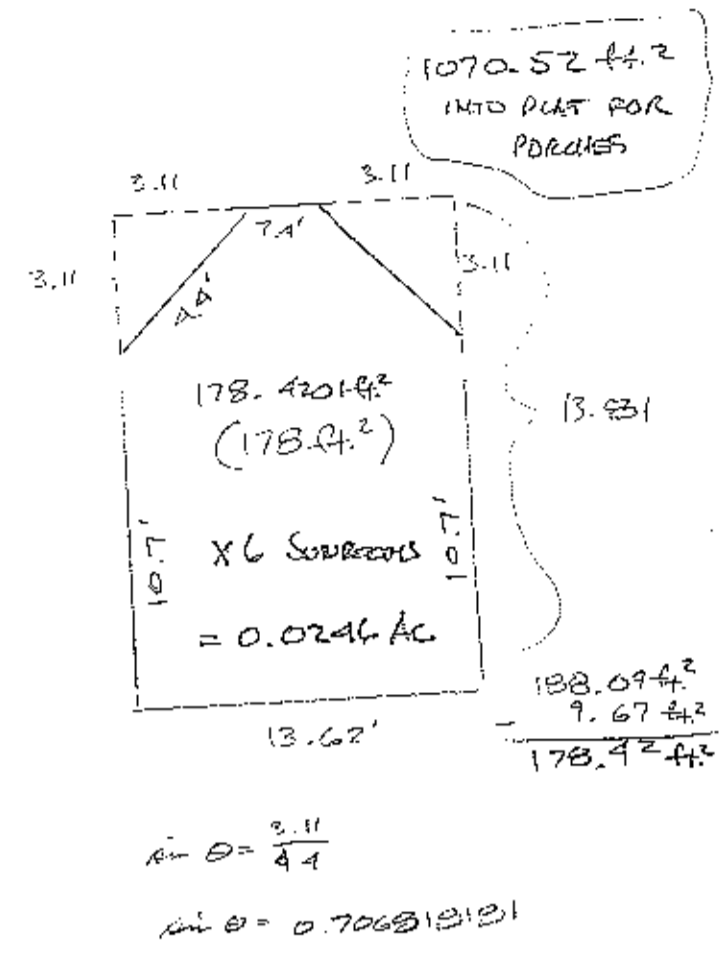
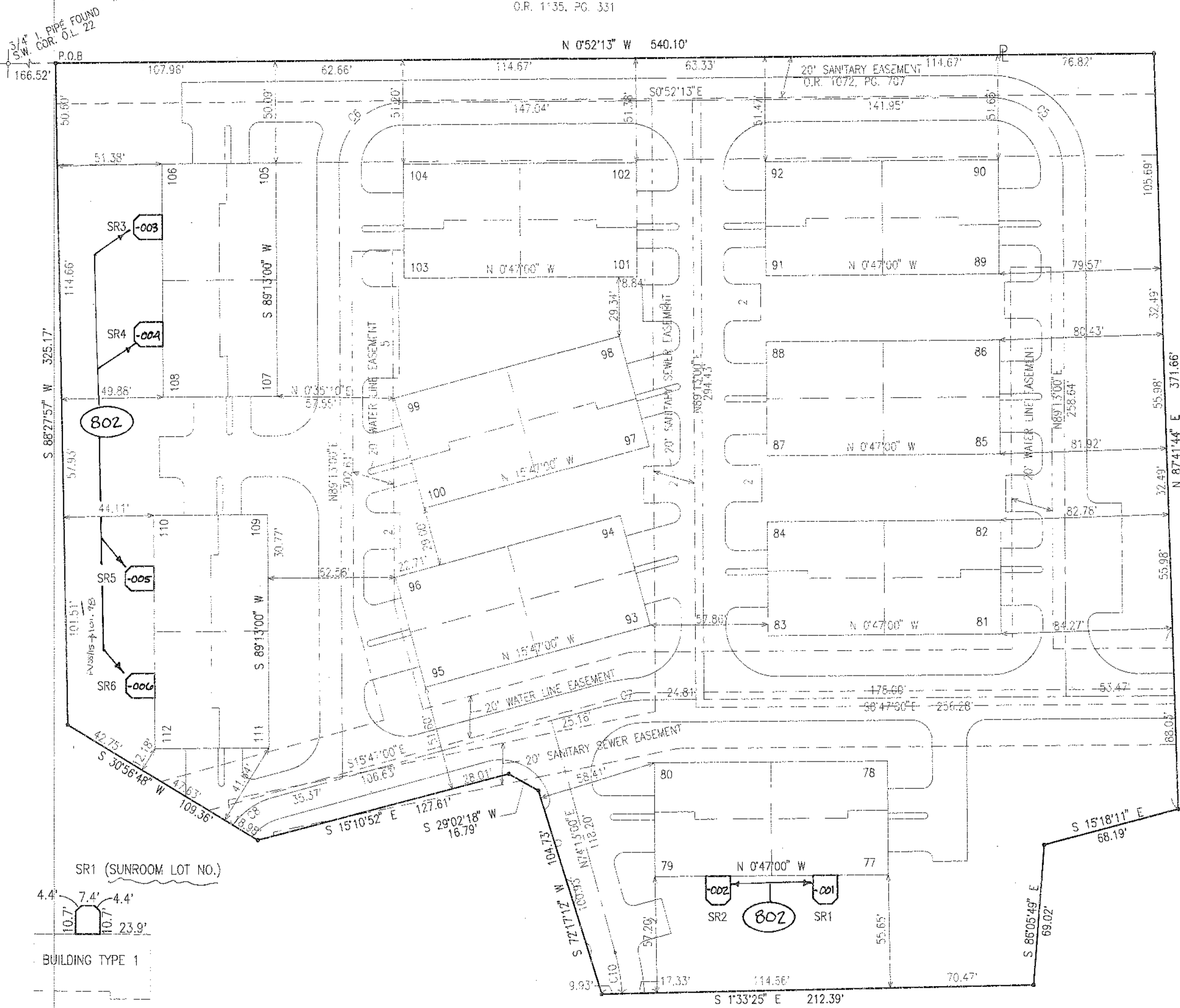

NOTE: ALL DIMENSIONS SHOWN FROM PROPERTY LINES AND PHASE LINES ARE PERPENDICULAR UNLESS OTHERWISE NOTED.

**LEGAL DESCRIPTION**

PHASE 2  
PARCEL F SUNROOMS  
SITUATE IN THE STATE OF OHIO COUNTY OF LORAIN, CITY OF AVON, ORIGINAL AVON TOWNSHIP LOT NO. 22 AND BEING UNITS SR1, SR2, SR3, SR4, SR5 AND SR6 IN PHASE 1, PARCEL F, DEVONSHIRE MEADOWS SUBDIVISION; SAID PARCEL F BEING MORE PARTICULARLY DESCRIBED AS FOLLOWS:

BEGINNING, FOR REFERENCE, AT A 3/4" IRON PIPE FOUND AT THE SOUTHWESTERLY CORNER OF SAID ORIGINAL TOWNSHIP LOT NO. 22, THE SAME BEING THE NORTHWEST CORNER OF ORIGINAL LOT NO. 23; THENCE, N. 0°52'13" W., ALONG THE WEST LINE OF SAID LOT NO. 22, A DISTANCE OF 166.52 FEET TO THE TRUE POINT OF BEGINNING; THENCE, CONTINUING ALONG THE WEST LINE OF SAID LOT NO. 22, A DISTANCE OF 540.10 FEET TO A POINT; THENCE, N. 87°41'44" E., A DISTANCE OF 371.66 FEET TO A POINT; THENCE, S. 15°18'11" E., A DISTANCE OF 68.19 FEET TO A POINT; THENCE, S. 86°05'49" E., A DISTANCE OF 69.02 FEET; THENCE, S. 1°33'25" E., A DISTANCE OF 212.39 FEET TO A POINT; THENCE, S. 72°17'12" W., A DISTANCE OF 104.73 FEET TO A POINT; THENCE, S. 29°02'18" W., A DISTANCE OF 16.79 FEET TO A POINT; THENCE, S. 15°10'52" E., A DISTANCE OF 127.61 FEET TO A POINT; THENCE, S. 30°56'48" W., A DISTANCE OF 109.36 FEET TO A POINT; THENCE, S. 88°27'57" W., A DISTANCE OF 325.17 FEET TO THE POINT OF BEGINNING, CONTAINING 5.0433 ACRES OF LAND, MORE OR LESS, SUBJECT TO ALL LEGAL HIGHWAYS.

#21592

APPROVED  
LORAIN CO.  
MAP DEPT.  
DATE 12-22-95  
PAGE 4 OF 02-2-E  
BY T. McHain  
WORD AFTER 21592

**LEGEND**

- MONUMENT FOUND AS NOTED
- 1/2" IRON ROD SET

OUT OF 04-00-022-801-132 3.71 A.  
INTO PLAT - 0.02 A.  
REMAINDER 04-00-022-800-001 3.69

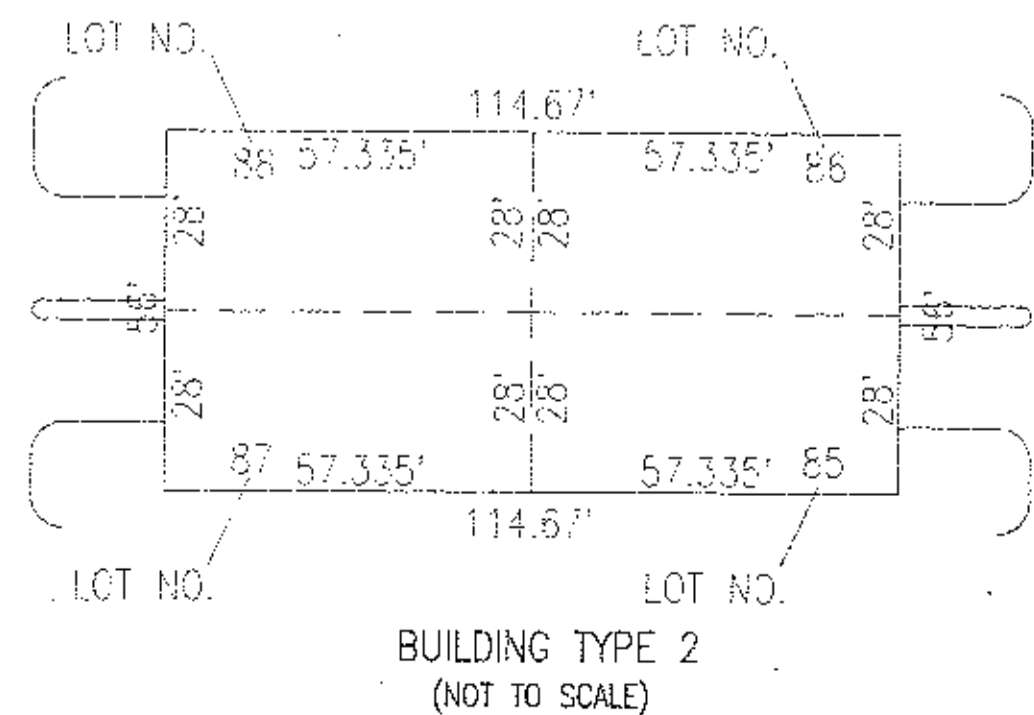
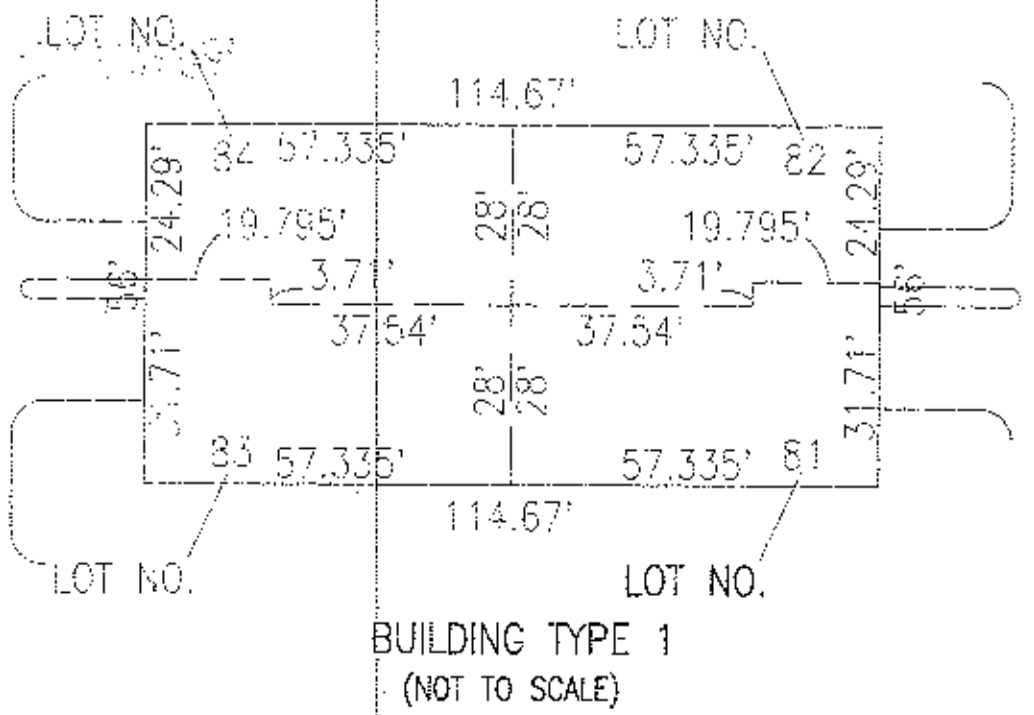

**CURVE TABLE**

CURVE NO.	RADIUS	DELTA	ARC	TAN	CHORD
C5	36.00	90°05'13"	56.60	36.05	S 44°10'24" W 50.95
C6	31.00	89°54'47"	48.65	30.95	S 44°01'31" E 42.49
C7	100.00	15°00'00"	26.18	13.17	S 8°17'00" E 26.11
C8	36.00	38°49'18"	24.39	12.66	S 33°11'39" E 23.93
C10	100.00	11°47'45"	20.59	10.33	S 80°06'53" E 20.55

*John Hancock & Associates*  
416 COLUMBUS AVENUE SANDUSKY, OHIO 44870  
(419) 625-7838

DEVONSHIRE MEADOWS SUBDIVISION  
PHASE 2 - PARCEL F SUNROOMS  
SHEET 2 OF 2

SCALE: 1" = 30'  
DRAWN BY: JRK

FILE No.: 75794-38  
DATE: 11/21/95

#380215

JOHN & JOHANNA MUELLER  
O.R. 1'35, PG. 331

#380215

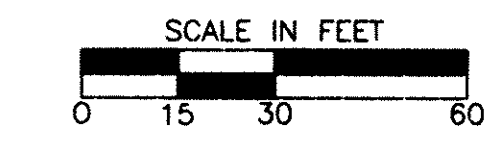
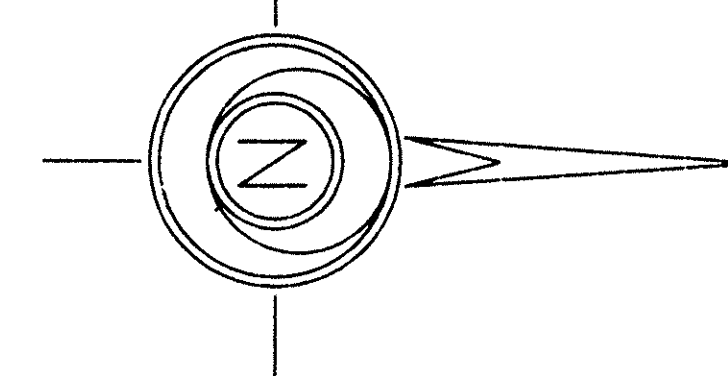

NOTE: ALL DIMENSIONS SHOWN FROM PROPERTY LINES AND PHASE LINES ARE PERPENDICULAR UNLESS OTHERWISE NOTED.

**LEGAL DESCRIPTION**

PHASE 2  
PARCEL F SUNROOMS  
SITUATE IN THE STATE OF OHIO COUNTY OF LORAIN, CITY OF AVON, ORIGINAL AVON TOWNSHIP LOT NO. 22 AND BEING UNITS SR1, SR2, SR3, SR4, SR5 AND SR6 IN PHASE 1, PARCEL F, DEVONSHIRE MEADOWS SUBDIVISION; SAID PARCEL F BEING MORE PARTICULARLY DESCRIBED AS FOLLOWS:

BEGINNING, FOR REFERENCE, AT A 3/4" IRON PIPE FOUND AT THE SOUTHWESTERLY CORNER OF SAID ORIGINAL TOWNSHIP LOT NO. 22, THE SAME BEING THE NORTHWEST CORNER OF ORIGINAL LOT NO. 23; THENCE, N. 0°52'13" W., ALONG THE WEST LINE OF SAID LOT NO. 22, A DISTANCE OF 166.52 FEET TO THE TRUE POINT OF BEGINNING; THENCE, CONTINUING ALONG THE WEST LINE OF SAID LOT NO. 22, A DISTANCE OF 540.10 FEET TO A POINT; THENCE, N. 87°41'44" E., A DISTANCE OF 371.66 FEET TO A POINT; THENCE, S. 15°18'11" E., A DISTANCE OF 68.19 FEET TO A POINT; THENCE, S. 86°05'49" E., A DISTANCE OF 69.02 FEET; THENCE, S. 1°33'25" E., A DISTANCE OF 212.39 FEET TO A POINT; THENCE, S. 72°17'12" W., A DISTANCE OF 104.73 FEET TO A POINT; THENCE, S. 29°02'18" W., A DISTANCE OF 16.79 FEET TO A POINT; THENCE, S. 15°10'52" E., A DISTANCE OF 127.61 FEET TO A POINT; THENCE, S. 30°56'48" W., A DISTANCE OF 109.36 FEET TO A POINT; THENCE, S. 88°27'57" W., A DISTANCE OF 325.17 FEET TO THE POINT OF BEGINNING, CONTAINING 5.0433 ACRES OF LAND, MORE OR LESS, SUBJECT TO ALL LEGAL HIGHWAYS.

**LEGEND**

- MONUMENT FOUND AS NOTED
- 1/2" IRON ROD SET

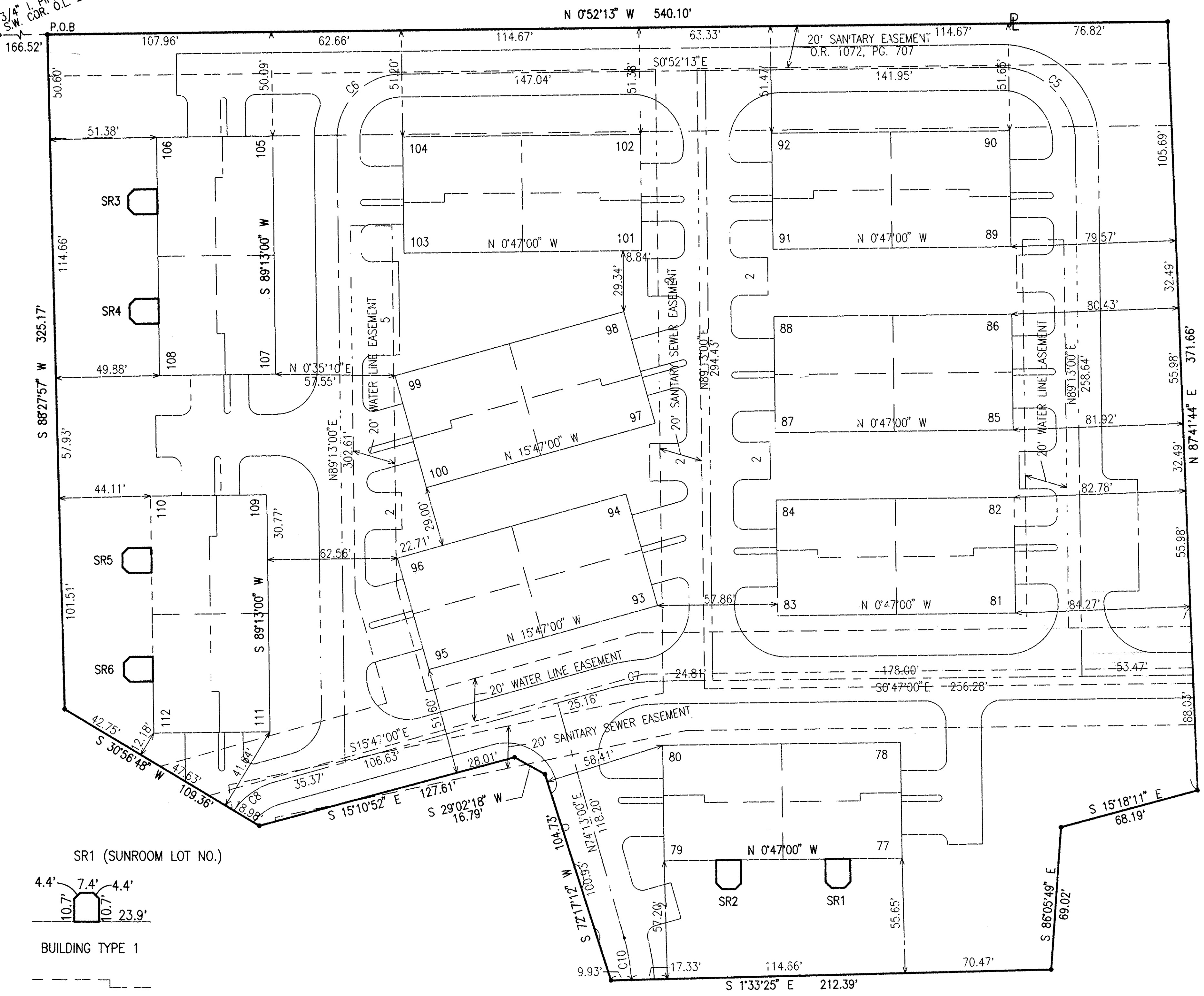

SR1 (SUNROOM LOT NO.)

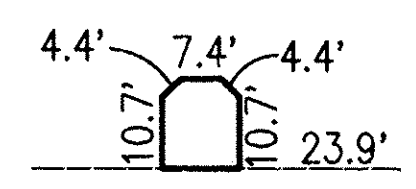

BUILDING TYPE 1

TYPICAL SUNROOM (NOT TO SCALE)

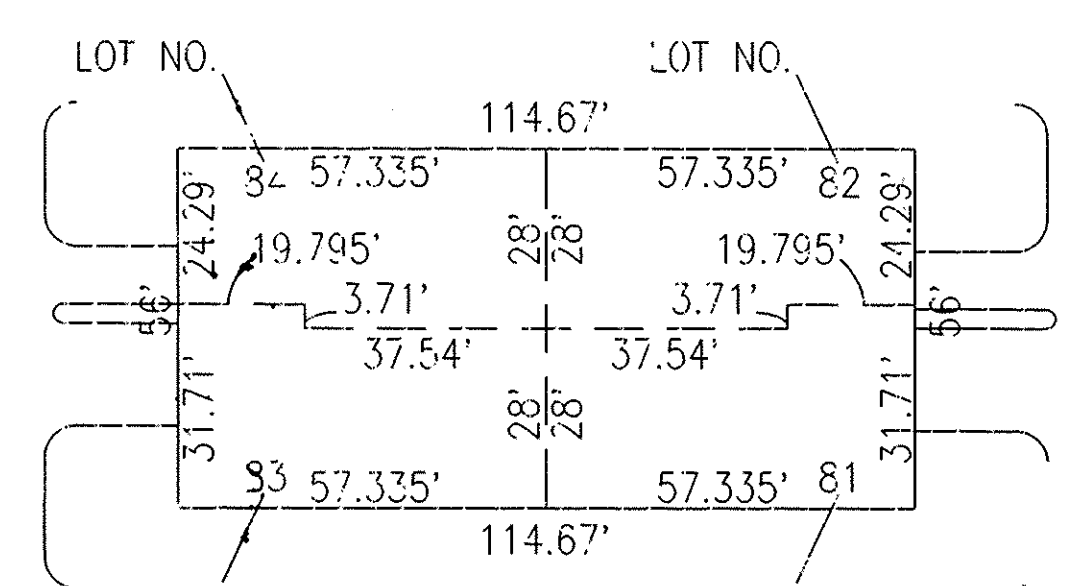

BUILDING TYPE 1 (NOT TO SCALE)

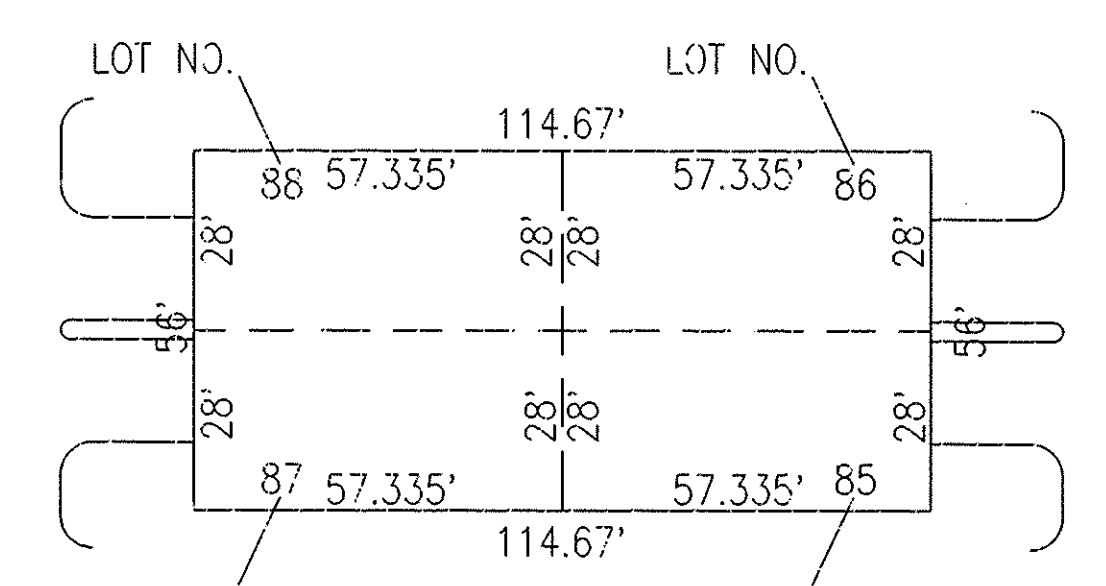

BUILDING TYPE 2 (NOT TO SCALE)

**CURVE TABLE**

CURVE NO.	RADIUS	DELTA	ARC	TAN	CHORD
C5	36.00	90°05'13"	56.60	36.05	S 44°10'24" W 50.95
C6	31.00	89°54'47"	48.65	30.95	S 44°01'31" E 42.49
C7	100.00	15°00'00"	26.18	13.17	S 8°17'00" E 26.11
C8	36.00	38°49'18"	24.39	12.69	S 35°11'39" E 23.93
C10	100.00	11°47'45"	20.59	10.33	S 80°06'53" E 20.55

LORAIN COUNTY TAX  
MAP DEPARTMENT COPY

*John Hancock & Associates*  
416 COLUMBUS AVENUE SANDUSKY, OHIO 44870  
(419) 625-7838

DEVONSHIRE MEADOWS SUBDIVISION  
PHASE 2 - PARCEL F SUNROOMS  
SHEET 2 OF 2

SCALE: 1" = 30'  
DRAWN BY: JRK  
FILE NO.: 75794-38  
DATE: 11/21/95