

26/59

790629

790629

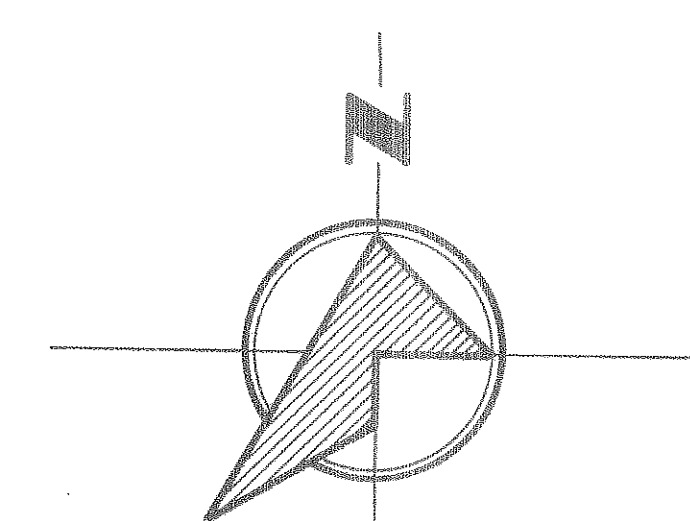

ANTONETTE STREET 60'

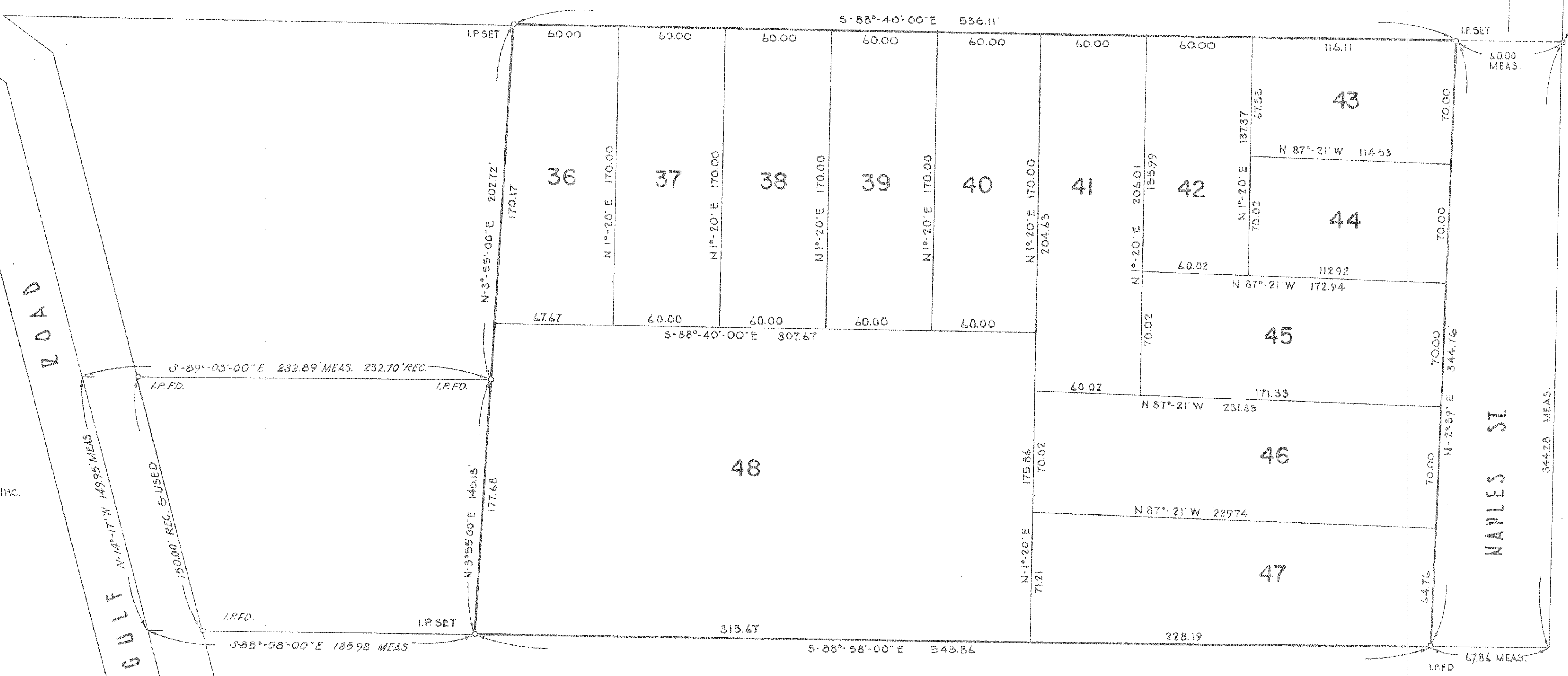

**SURVEYORS CERTIFICATE:**

THIS IS TO CERTIFY THAT AT THE REQUEST OF THE OWNERS, WE HAVE SURVEYED AND PLATTED GULF ROAD HEIGHTS ALLOTMENT No. 2 AS SHOWN HEREON, CONTAINING 4.290 ACRES OF LAND IN ORIGINAL LOT NO. 8 OF THE BURRELL AND DAY TRACT, ELYRIA TOWNSHIP, LORAIN COUNTY, OHIO. AT ALL POINTS SO DESIGNATED — IRON PIN MONUMENTS WERE FOUND OR SET. ALL MEASUREMENTS ARE IN FEET AND DECIMAL PARTS THEREOF. BEARINGS USED ARE ASSUMED AND ARE FOR PURPOSES OF DESCRIBING ANGLES ONLY, ALL OF WHICH I CERTIFY TO BE CORRECT.

*Norman E. Hura*  
NORMAN E. HURA  
REGISTERED SURVEYOR  
SCHAFER, HURA and ASSOCIATES, INC.

**OWNERS CERTIFICATE:**

THIS IS TO CERTIFY THAT I, MARY PIAZZA, ATTORNEY IN FACT FOR THE FOLLOWING, MARY PIAZZA, JOSEPHINE PIAZZA, PAULINE MARSIGLIA, ROSE KELLER, MARGARET HAYES, ANNETTE JEZEWSKI, ANN CAMM, LENA COILETTI, FRANCES SANCHEZ, OWNERS OF LANDS EMBRACED BY THE ABOVE PLAT OF GULF ROAD HEIGHTS ALLOTMENT No. 2 DO HEREBY ACCEPT SAME TO BE CORRECT.

*Mary Piazza*  
MARY PIAZZA  
ATTORNEY IN FACT

THIS IS TO CERTIFY THAT THE ABOVE PLAT OF GULF ROAD HEIGHTS ALLOTMENT No. 2 IS HEREBY ACCEPTED ON THIS 14<sup>th</sup> DAY OF October 1971 BY THE PLANNING COMMISSION OF THE CITY OF ELYRIA, OHIO.

*Richard K. Wilson* PRESIDENT  
*Mildred L. Keatley* SECRETARY

THIS IS TO CERTIFY THAT I HAVE EXAMINED THE ABOVE PLAT AND HEREBY APPROVE THE SAME. I FIND THE MONUMENTS SET ARE SUFFICIENT TO DEFINE THE STREETS AS SHOWN.

*R. K. Wilson*  
CITY ENGINEER, CITY OF ELYRIA

ANTONETTE STREET RECORDED IN GULF ROAD HEIGHTS ALLOTMENT VOLUME 16 PAGE 23 PRIOR TO ANNEXATION TO THE CITY OF ELYRIA, ANNEXED AUGUST 17, 1959. NAPLES DRIVE DEDICATED DEED TO CITY OF ELYRIA VOLUME 930 PAGE 616. NO DEDICATION ORDINANCE NECESSARY FOR EITHER STREET.

STATE OF OHIO }  
COUNTY OF LORAIN } ss.

BEFORE ME, A NOTARY PUBLIC IN AND FOR SAID COUNTY AND STATE DID PERSONALLY APPEAR, MARY PIAZZA, ATTORNEY IN FACT FOR, MARY PIAZZA, JOSEPHINE PIAZZA, PAULINE MARSIGLIA, ROSE KELLER, MARGARET HAYES, ANNETTE JEZEWSKI, ANN CAMM, LENA COILETTI, FRANCES SANCHEZ, WHO ACKNOWLEDGED THAT SHE DID SIGN THE FOREGOING PLAT AND THAT IT WAS OF HER OWN FREE ACT AND DEED, IN TESTIMONY WHERE OF I HEREBY SET MY HAND AND OFFICIAL SEAL ON THIS 10<sup>th</sup> DAY OF OCTOBER 1971.

*Robert D. Piazza*  
ROBERT D. PIAZZA  
NOTARY PUBLIC

MY COMMISSION EXPIRES N/A HAS NO EXPIRATION DATE

# GULF ROAD HEIGHTS ALLOTMENT No. 2

PART OF ORIGINAL LOT NO. 8

BURRELL and DAY TRACT

ELYRIA TOWNSHIP

CITY of ELYRIA

LORAIN COUNTY OHIO

SCALE: 1" = 40'

SEPTEMBER 1971

by

SCHAFFER, HURA & ASSOCIATES, INC.

CONSULTING ENGINEERS AND SURVEYORS

RECEIVED FOR RECORD

AT 11:30 AM

NOV-3 1971

RECORDED IN LORAIN

COUNTY RECORDS

Vol 26 Page 59

LESTA N. MITCHELL

Lorain County Auditor

26/59

17 28