

WALNUT RIDGE SUBDIVISION No. 1

SITUATED IN THE VILLAGE OF SHEFFIELD, COUNTY OF LORAIN, STATE OF OHIO, BEING PORTIONS OF LAND DESCRIBED IN A DEED TO WALNUT RIDGE HOLDINGS, LLC AS RECORDED IN INSTRUMENT NUMBER 2021-0842225 AND TO WALNUT RIDGE DEVELOPMENT, LLC AS RECORDED IN INSTRUMENT NUMBER 2021-0848795 OF THE LORAIN COUNTY DEED RECORDS. BEING PART OF ORIGINAL SHEFFIELD TOWNSHIP LOT NUMBERS 15 & 16.

OWNER'S CERTIFICATE:

SITUATED IN THE VILLAGE OF SHEFFIELD, COUNTY OF LORAIN, STATE OF OHIO, KNOWN AS BEING PART OF ORIGINAL SHEFFIELD TOWNSHIP LOT NUMBERS 15 & 16. BEING PORTIONS OF LAND DESCRIBED IN A DEED TO WALNUT RIDGE HOLDINGS, LLC AS RECORDED IN INSTRUMENT NUMBER 2021-0842225 AND TO WALNUT RIDGE DEVELOPMENT, LLC AS RECORDED IN INSTRUMENT NUMBER 2021-0848795 OF THE LORAIN COUNTY DEED RECORDS. CONTAINING WITHIN SAID BOUNDS 15.2351 ACRES OF LAND WITH IN THE SUBDIVISION.

THE UNDERSIGNED, DOES HEREBY CERTIFY THAT THE PLAT SHOWN HEREON REPRESENTS "WALNUT RIDGE SUBDIVISION No. 1", SUBLOT NUMBERS 1 THRU 35 AND BLOCKS "A", "B" & "C", SITUATED IN THE VILLAGE OF SHEFFIELD, COUNTY OF LORAIN, STATE OF OHIO, KNOWN AS BEING PART OF ORIGINAL SHEFFIELD TOWNSHIP LOT NUMBERS 15 & 16.

THE UNDERSIGNED AGREES THAT THE ROADWAYS SHOWN WITHIN THE SUBDIVISION AREA AS SHOWN HEREON SHALL REMAIN PRIVATE AND ARE NOT DEDICATED AS PUBLIC ROADWAYS. ALL ACCESS AND MAINTENANCE OF ROADWAYS SHOWN HEREON SHALL BE HANDLED UNDER WRITTEN AND RECORDED EASEMENT DOCUMENTS.

THE UNDERSIGNED FURTHER AGREES THAT ANY USE OR IMPROVEMENTS MADE ON THIS LAND SHALL BE IN THE CONFORMITY WITH ALL EXISTING PLATTING, ZONING, HEALTH OR OTHER LAWFUL RULES AND REGULATIONS INCLUDING THE APPLICABLE OFF-STREET LOADING AND PARKING REQUIREMENTS OF SHEFFIELD VILLAGE, OHIO FOR THE BENEFIT OF THEMSELVES AND ALL OTHER SUBSEQUENT PARTIES TAKING TITLE FROM, UNDER, OR THROUGH THE UNDERSIGNED.

EASEMENTS ARE RESERVED WHERE INDICATED ON THIS PLAT FOR PRIVATE UTILITY PURPOSES ABOVE AND BELOW THE SURFACE OF THE GROUND.

IN WITNESS WHEREOF THE UNDERSIGNED HAVE HEREUNTO SET THEIR HANDS

THIS: 8 DAY OF January, 2024

Patrick J. Shenigo
 PATRICK J. SHENIGO
 MANAGER
 WALNUT RIDGE HOLDINGS, LLC
 WALNUT RIDGE DEVELOPMENT, LLC

NOTARY SEAL:

STATE OF OHIO
 COUNTY OF LORAIN S.S.

BEFORE ME, A NOTARY PUBLIC IN AND FOR SAID COUNTY AND STATE DID PERSONALLY APPEAR PATRICK J. SHENIGO MANAGER OF WALNUT RIDGE HOLDINGS, LLC & WALNUT RIDGE DEVELOPMENT, LLC WHO ACKNOWLEDGED THE SIGNING OF THIS PLAT TO BE HIS FREE ACT AND DEED FOR THE USES AND PURPOSES HEREON EXPRESSED.

IN WITNESS THEREOF I HAVE HEREUNTO SET MY HAND AND OFFICIAL SEAL

THIS: 8th DAY OF January, 2024

Denise M. Alexander
 NOTARY PUBLIC

07/20/2027
 MY COMMISSION EXPIRES

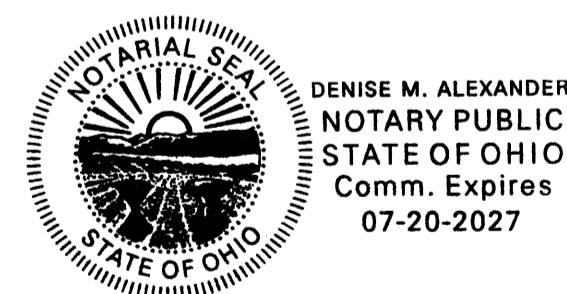

REFERENCES USED

- SUBJECT & ADJACENT PARCEL RECORDINGS AS LISTED HEREON
- LORAIN COUNTY TAX MAPS (CURRENT AND 1962 MAPS)
- LOR-301-24-37 CENTERLINE PLAT DATED OCTOBER 11, 1994.
- LOR-301-24-37 P.L.D. 4032 RIGHT-OF-WAY PLANS DATED SEPTEMBER 6, 1995.
- PLAT OF SURVEY & PARTITION FOR DURHAM HOLDINGS, LTD., NEFF & ASSOCIATES THOMAS J. NEFF, JR., P.S. 7065, DATED SEPTEMBER 15, 2006.
- PLAT OF PROPOSED PROPERTY TO BE ACQUIRED FOR THE LAKE ERIE & PITTSBURGH RAILWAY COMPANY, LOR-90-13.01, DATED APRIL 4, 1968.
- BOUNDARY SURVEY FOR CONSOLIDATED RAIL CORPORATION, MANNIK & SMITH INC. JAMES A. BROADWAY P.S. 6309, DATED JANUARY 16, 1990.

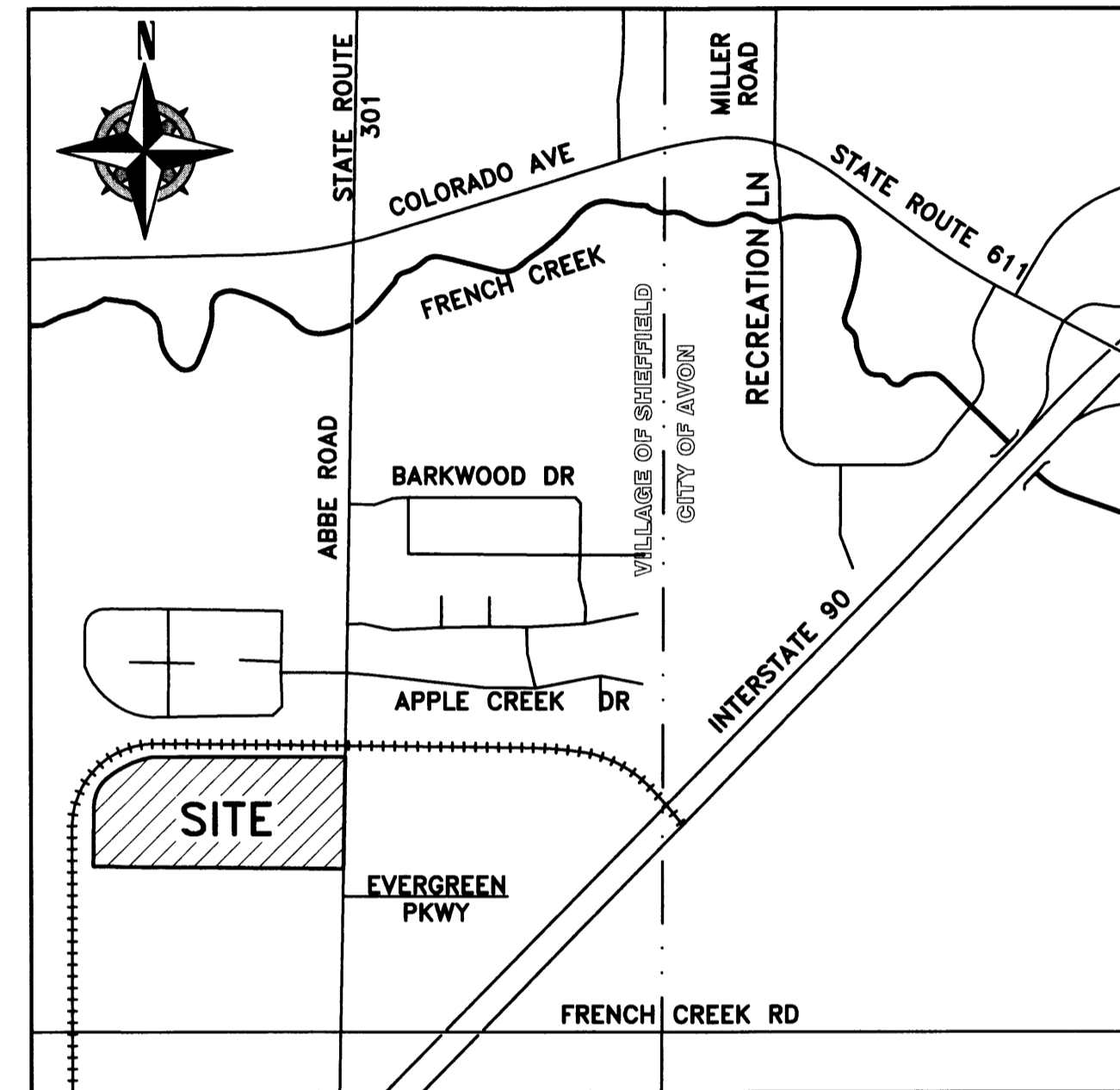

VICINITY MAP
 -NOT TO SCALE-

SURVEYOR'S CERTIFICATE:

THIS IS TO CERTIFY THAT AT THE REQUEST OF THE OWNER(S), I HAVE SURVEYED AND PLATTED "WALNUT RIDGE SUBDIVISION No. 1", SUBLOT NUMBERS 1 THRU 35 AND BLOCKS "A", "B" & "C", SITUATED IN THE VILLAGE OF SHEFFIELD, COUNTY OF LORAIN, STATE OF OHIO, KNOWN AS BEING PART OF ORIGINAL SHEFFIELD TOWNSHIP LOT NUMBERS 15 & 16. BEING PORTIONS OF LAND DESCRIBED IN A DEED TO WALNUT RIDGE HOLDINGS, LLC AS RECORDED IN INSTRUMENT NUMBER 2021-0842225 AND TO WALNUT RIDGE DEVELOPMENT, LLC AS RECORDED IN INSTRUMENT NUMBER 2021-0848795 OF THE LORAIN COUNTY DEED RECORDS. CONTAINING WITHIN SAID BOUNDS 15.2351 ACRES OF LAND WITH IN THE SUBDIVISION. ALL POINTS WERE FOUND OR SET AS INDICATED HEREON. DISTANCES ARE SHOWN IN FEET AND DECIMAL PARTS THEREOF.

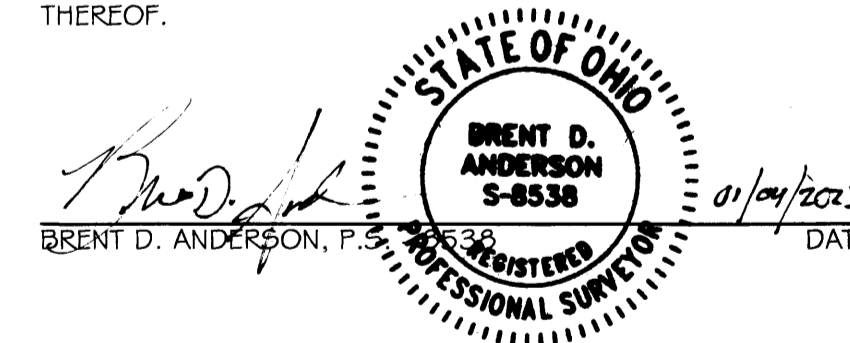

This Deed approved by Sheffield Village as not being in violation of Chapter 711 of the Ohio Revised Code.
[Signature] ADMINSTRATOR
 SHEFFIELD VILLAGE

TRANSFERRED
 IN COMPLIANCE WITH SSC 319-202
 OHIO REV. CODE
 FEB 02 2024 Jw Exempt
 AV

J. CRAIG SNOODGRASS, CPA, CGFM
 LORAIN COUNTY AUDITOR

2024-0002852
 PLAT Fee: \$432.00 Page 1 of 6
 Recorded: 2/2/2024 at 01:53 PM
 Receipt: T20240002842
 Lorain County Recorder Mike Doran

Plat Vol 115
 Pg 11, 12, 13, 14, 15

VILLAGE OF SHEFFIELD APPROVALS:

VILLAGE ADMINISTRATOR:
 THIS PLAT IS HEREBY APPROVED, THIS 16th DAY OF JANUARY, 2024

[Signature]
 SHEFFIELD VILLAGE ADMINISTRATOR
 DATE: January 16, 2024

LEGEND:

- O IRON PIN/PIPE FOUND AS NOTED
- REBAR SET WITH YELLOW CAP STAMPED "RAFTER A, LTD CORNER PIN" OR GREEN CAP STAMPED "RAFTER A, LTD LINE PIN"
- ☒ MONUMENT BOX FOUND WITH IRON PIN/PIPE FOUND AS NOTED
- RAILROAD SPIKE FOUND AS NOTED
- M.N.S. MAGNETIC NAIL/SPIKE SET
- ✕ D.H.S. DRILL HOLE SET
- ⊙ REBAR SET IN 2020 WITH CAP STAMPED "RAFTER A, LTD"
- P/L PROPERTY LINE
- C/L CENTERLINE
- R/W RIGHT-OF-WAY

BASIS OF BEARINGS

BASIS OF BEARING IS ASSUMED AND IS USED TO DESCRIBE ANGLES ONLY. A PORTION OF THE CURRENT CENTERLINE OF ABBE ROAD AND IS ASSUMED TO BE NORTH 00° 38' 50" EAST AS SHOWN HEREON.

THIS SURVEY IS BASED UPON A FIELD SURVEY PERFORMED BY RAFTER A., LTD IN MARCH THRU APRIL OF 2021.

ACREAGE BREAKDOWN

PRE-SUBDIVISION	
PPN: 03-00-016-000-009:	25.2446 ACRES
PPN: 03-00-015-000-062:	8.5103 ACRES
PPN: 03-00-015-000-063:	38.9757 ACRES
OVERALL SITE ACREAGE:	72.7306 ACRES

POST-SUBDIVISION	
SUBLOT NUMBERS 1-35:	11.8206 ACRES
BLOCK "A":	0.8922 ACRES
BLOCK "B":	0.1614 ACRES
BLOCK "C":	2.3609 ACRES
WALNUT RIDGE SUB NO. 1:	15.2351 ACRES

RIGHT-OF-WAY AREA A:	0.4684 ACRES
RIGHT-OF-WAY AREA B:	0.3935 ACRES
RIGHT-OF-WAY AREA C:	0.2223 ACRES
RIGHT-OF-WAY AREA TOTAL:	1.0842 ACRES (TO VILLAGE)

REMAINDER AREA A:	24.7761 ACRES
REMAINDER AREA B:	8.4659 ACRES
REMAINDER AREA C:	23.1693 ACRES

REV.	BY	DATE	DESCRIPTION
1	BDA	12-12-2023	PRELIMINARY ISSUE
2	BDA	12-26-2023	REVISED PER CLIENT COMMENTS, ISSUE FOR SIGNATURES
3	BDA	01-04-2024	REVISED VILLAGE APPROVAL

RAFTER A, LTD
 LAND SURVEYING • ENGINEERING • TESTING
 42683 Oberlin-Elyria Road, Oberlin, Ohio 44074
 440-707-4914 • www.raftera.com • info@raftera.com

WALNUT RIDGE HOLDINGS, LLC
 WALNUT RIDGE DEVELOPMENT, LLC
 440 TIMBER HILLS COMMONS DRIVE
 SANDUSKY, OHIO 44870
 PHONE: (419) 626-4677

WALNUT RIDGE
 SUBDIVISION No. 1
 TITLE SHEET
 VILLAGE OF SHEFFIELD, COUNTY OF
 LORAIN, STATE OF OHIO

DRAWN BY: BDA
 CHECKED BY: RAF
 RAF JOB No: 2529-21

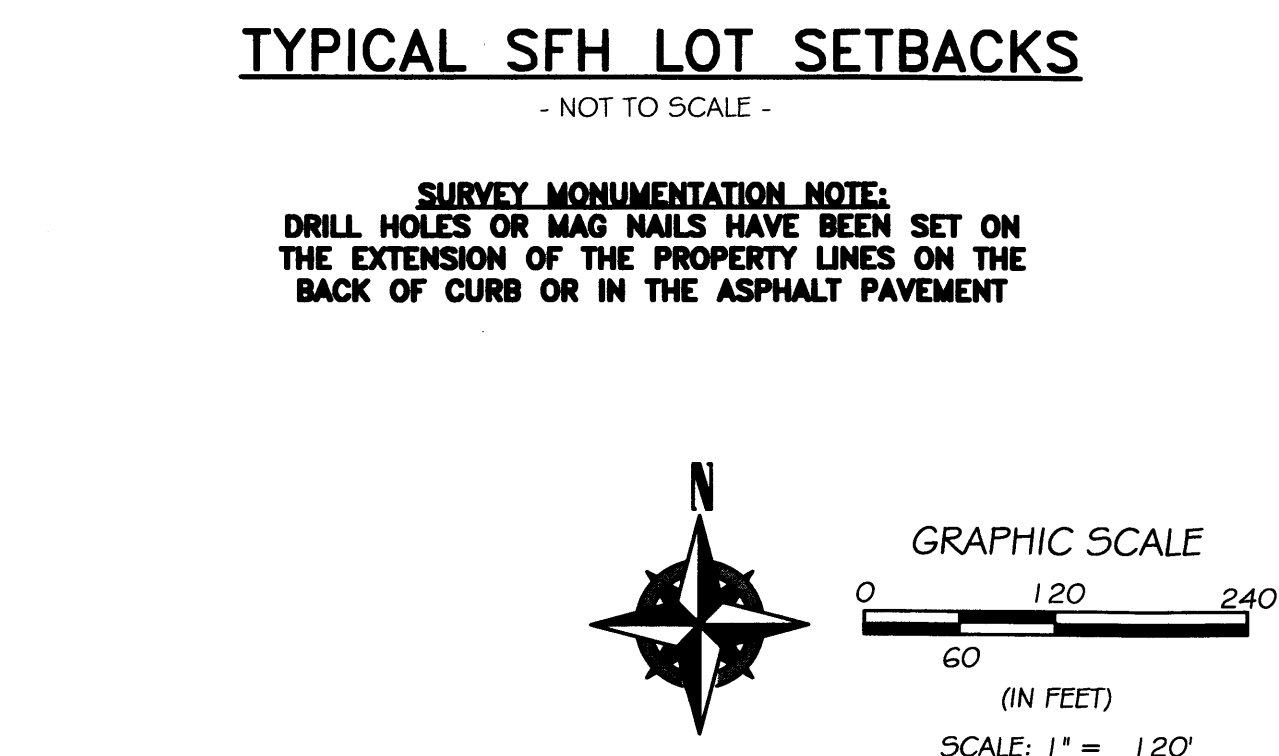
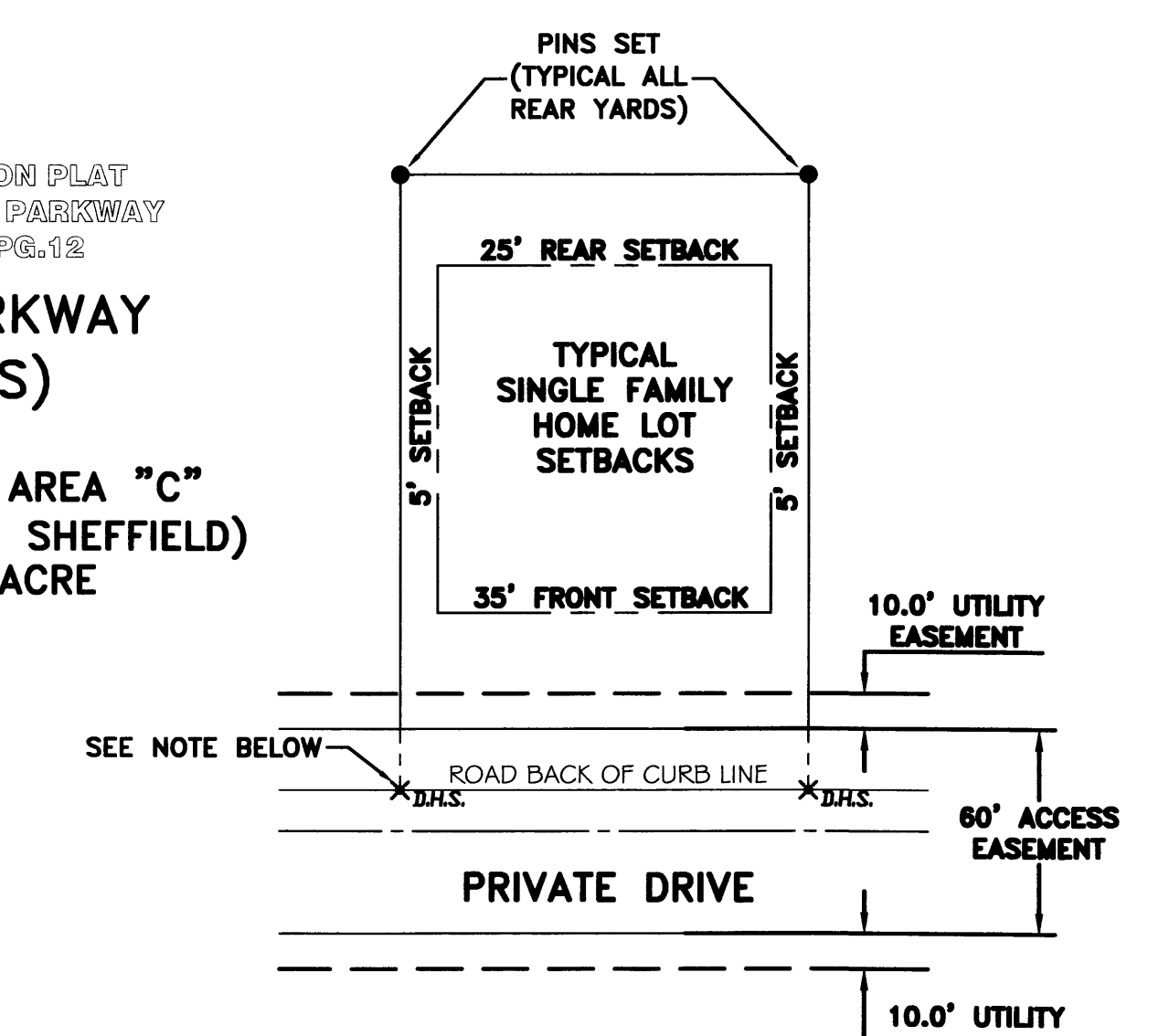
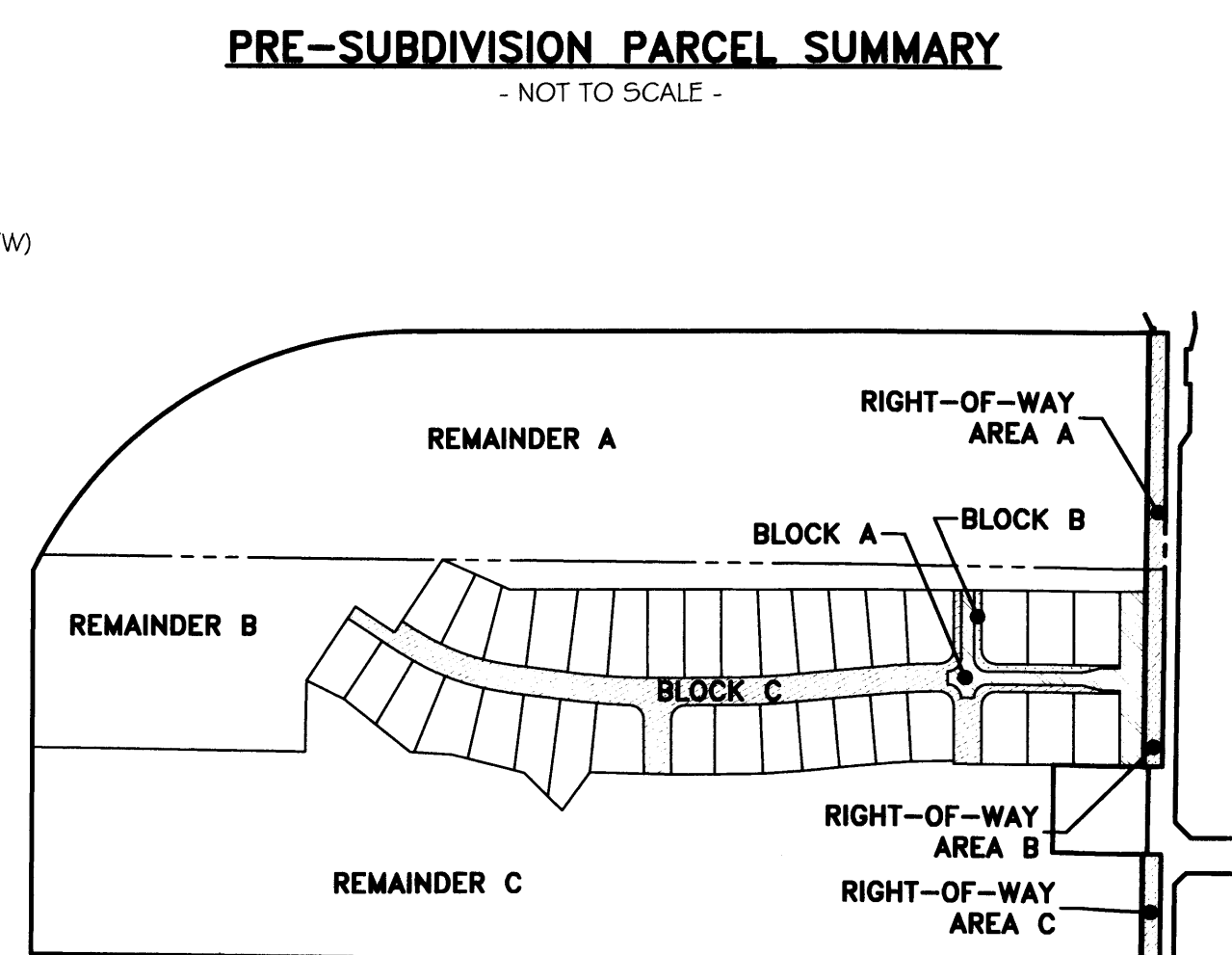
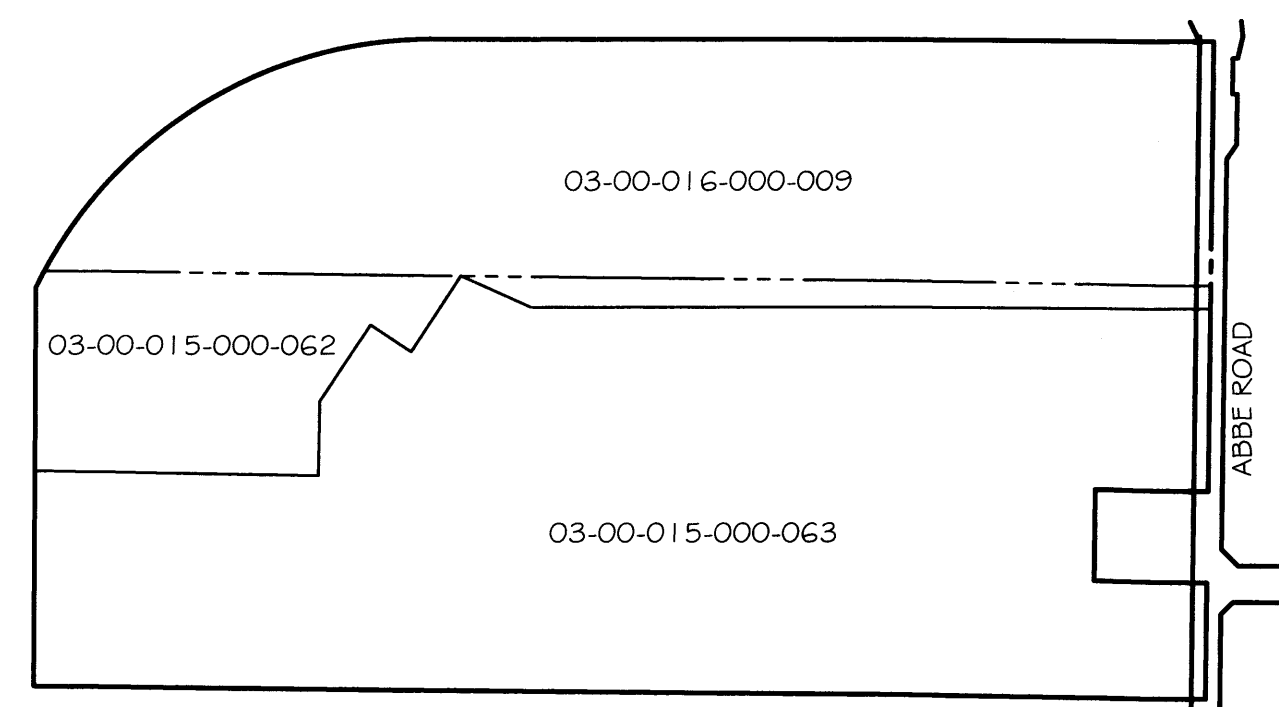
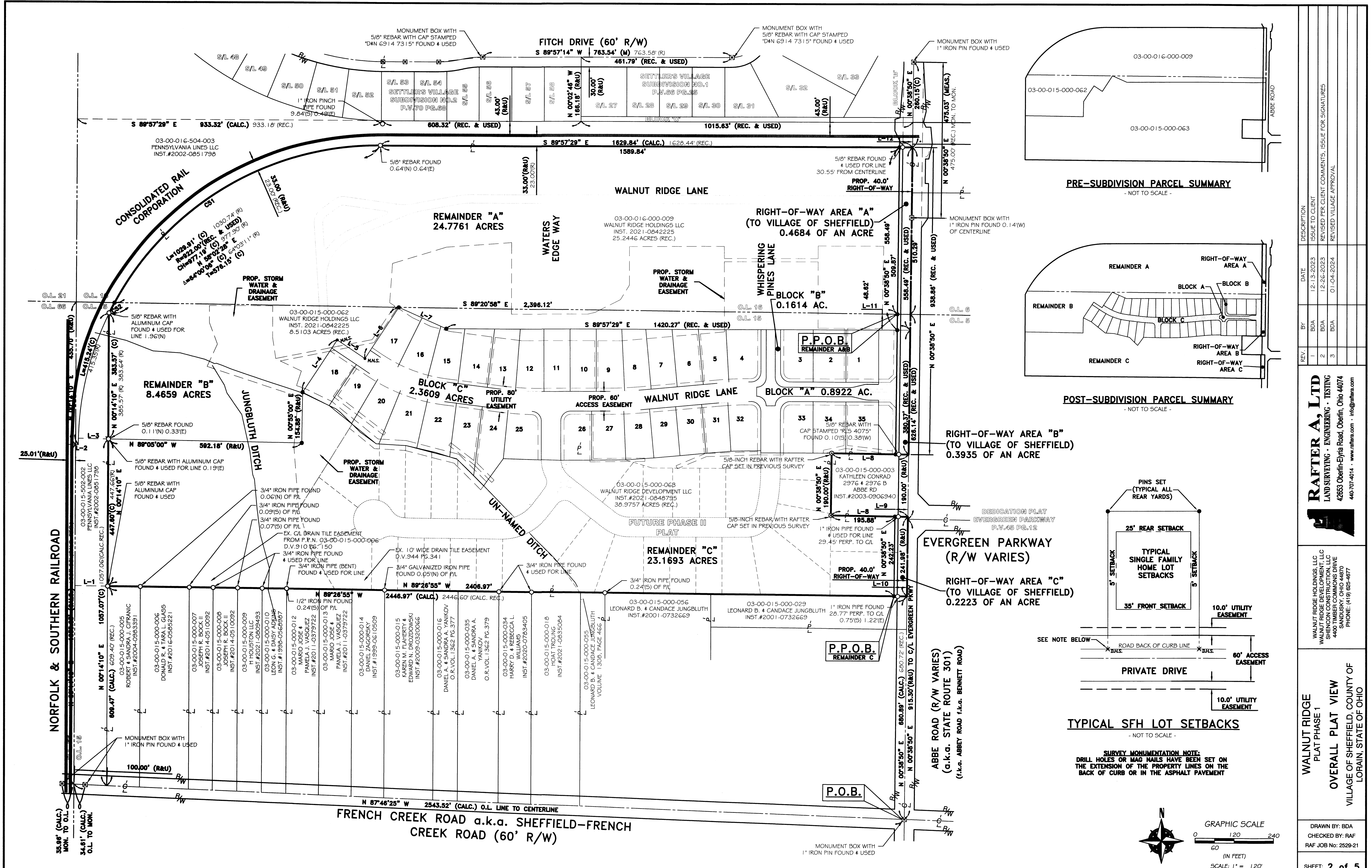

REV.	BY	DATE	DESCRIPTION
1	BDA	12-13-2023	ISSUE TO CLIENT
2	BDA	12-26-2023	REVISED PER CLIENT COMMENTS, ISSUE FOR SIGNATURES
3	BDA	01-04-2024	REVISED VILLAGE APPROVAL

RAFTER A, LTD
 LAND SURVEYING - ENGINEERING - TESTING
 42665 Oberlin-Elyria Road, Oberlin, Ohio 44074
 440-707-4014 - www.raftera.com - info@raftera.com

WALNUT RIDGE HOLDINGS, LLC
 WALNUT RIDGE DEVELOPMENT, LLC
 SHERCON CONSTRUCTION, LLC
 4400 TIMBER COMMONS DRIVE
 SANDUSKY, OHIO 44870
 PHONE: (419) 625-4677

WALNUT RIDGE PLAT PHASE 1
OVERALL PLAT VIEW
 VILLAGE OF SHEFFIELD, COUNTY OF LORAIN, STATE OF OHIO

DRAWN BY: BDA
 CHECKED BY: RAF
 RAF JOB No: 2529-21

SHEET: **2** of 5

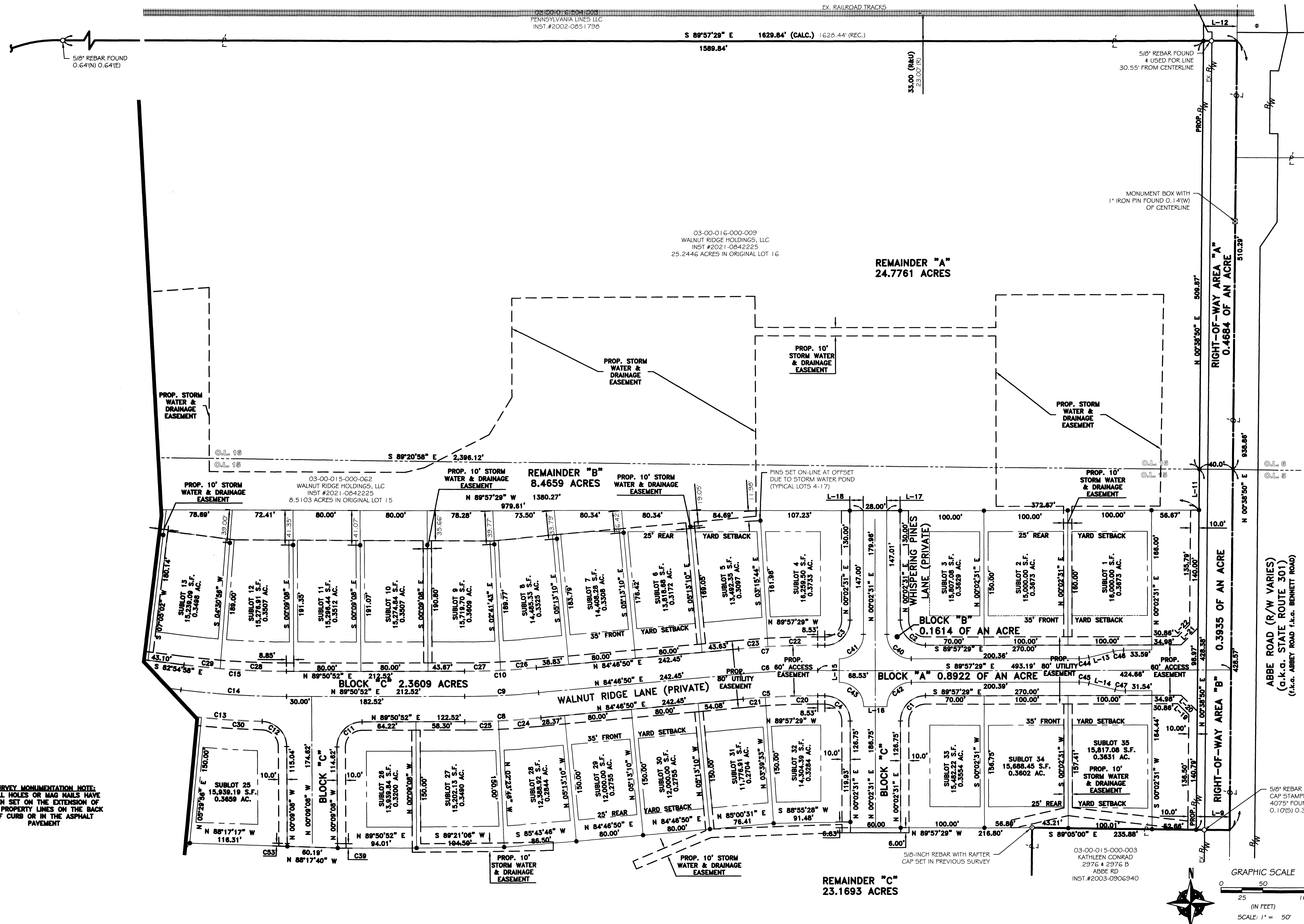

REV.	BY	DATE	DESCRIPTION
1	BDA	12-13-2023	ISSUE TO CLIENT
2	BDA	12-21-2023	REVISED PER CLIENT COMMENTS
3	BDA	01-04-2024	REVISED VILLAGE APPROVAL

RAFTER A, LTD
 LAND SURVEYING • ENGINEERING • TESTING
 42663 Oberlin-Flynn Road, Oberlin, Ohio 44074
 440-707-4014 • www.raftera.com • info@raftera.com

WALNUT RIDGE HOLDINGS, LLC
 WALNUT RIDGE DEVELOPMENT, LLC
 SHENCON CONSTRUCTION, LLC
 4400 TIMBER COMMONS DRIVE
 WILSON, OHIO 44097
 PHONE: (419) 665-4677

WALNUT RIDGE
 PLAT PHASE 1
ENLARGED PLAT VIEW
 VILLAGE OF SHEFFIELD, COUNTY OF LORAIN, STATE OF OHIO

DRAWN BY: BDA
 CHECKED BY: RAF
 RAF JOB No: 2529-21
 SHEET: 3 of 5

SURVEY MONUMENTATION NOTE:
 DRILL HOLES OR MAG NAILS HAVE BEEN SET ON THE EXTENSION OF THE PROPERTY LINES ON THE BACK OF CURB OR IN THE ASPHALT PAVEMENT

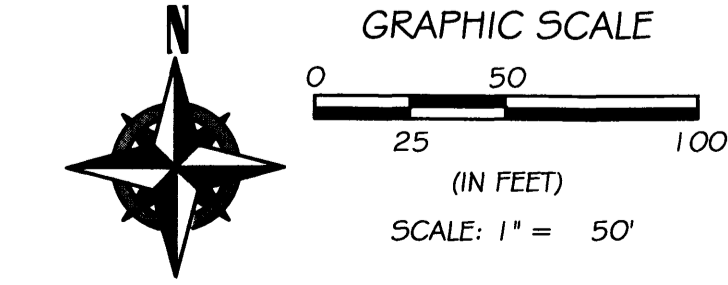

03-00-016-000-009
 WALNUT RIDGE HOLDINGS, LLC
 INST #2021-0842225
 25.2446 ACRES IN ORIGINAL LOT 16

REMAINDER "A"
 24.7761 ACRES

03-00-015-000-062
 WALNUT RIDGE HOLDINGS, LLC
 INST #2021-0842225
 8.5103 ACRES IN ORIGINAL LOT 15

REMAINDER "B"
 8.4659 ACRES

03-00-015-000-063
 WALNUT RIDGE DEVELOPMENT, LLC
 INST #2021-0848795
 38.9757 ACRES (REC.)

REMAINDER "C"
 23.1693 ACRES

BLOCK "C" 2.3609 ACRES

PARCEL LINE TABLE		
LINE #	LENGTH	DIRECTION
L-1	99.94' (C) 99.95' (R)	N 89°26'55" W
L-2	8.00' (R&U)	N 89°45'50" W
L-3	91.75' (C) 91.87' (R)	N 89°05'00" W
L-4	192.02' (R&U)	N 33°29'14" E
L-5	101.59' (R&U)	N 56°30'46" W
L-6	188.62' (R&U)	N 33°18'03" E
L-7	158.97' (R&U)	S 65°53'34" E
L-8	235.88' (R&U)	S 89°05'00" E
L-9	40.00'	N 89°05'00" W
L-10	40.00'	N 89°26'55" W
L-11	48.62'	N 00°38'50" E
L-12	40.00'	S 89°57'29" E
L-13	30.21'	N 76°20'03" E
L-14	32.29'	N 76°15'00" W
L-15	28.00'	N 00°02'31" E
L-16	28.00'	N 89°53'29" W
L-17	16.00'	N 89°57'29" W
L-18	28.00'	N 89°57'29" W
L-19	18.62'	S 45°15'38" E
L-20	26.96'	S 45°15'38" E
L-21	28.43'	S 45°20'41" W
L-22	20.21'	S 45°20'41" W

PARCEL CURVE TABLE						
CURVE #	ARC LENGTH	RADIUS	CHORD LENGTH	CHORD DIRECTION	TANGENT	DELTA
C1	47.12'	30.00'	42.43'	N 45°02'31" E	30.00'	90°00'00"
C2	47.12'	30.00'	42.43'	S 44°57'29" E	30.00'	90°00'00"
C3	47.12'	30.00'	42.43'	N 45°02'31" E	30.00'	90°00'00"
C4	47.12'	30.00'	42.43'	S 44°57'29" E	30.00'	90°00'00"
C5	89.07'	970.00'	89.04'	N 87°24'41" E	44.57'	5°15'41"
C6	91.83'	1000.00'	91.80'	N 87°24'41" E	45.95'	5°15'41"
C7	94.58'	1030.00'	94.55'	N 87°24'41" E	47.32'	5°15'41"
C8	91.09'	1030.00'	91.06'	N 87°18'51" E	45.57'	5°04'01"
C9	88.44'	1000.00'	88.41'	N 87°18'51" E	44.25'	5°04'01"
C10	85.78'	970.00'	85.75'	N 87°18'51" E	42.92'	5°04'01"
C11	47.12'	30.00'	42.43'	N 44°50'52" E	30.00'	90°00'00"
C12	46.27'	30.00'	41.82'	N 44°20'29" W	29.16'	88°22'42"
C13	100.93'	1030.00'	100.89'	N 85°43'24" W	50.50'	5°36'52"
C14	126.29'	1000.00'	126.21'	S 86°32'03" E	63.23'	7°14'10"
C15	122.51'	970.00'	122.42'	S 86°32'03" E	61.33'	7°14'10"
C17	244.24'	530.00'	242.08'	N 69°42'52" W	124.33'	26°24'13"
C18	230.41'	500.00'	228.38'	S 69°42'52" E	117.29'	26°24'13"
C19	216.59'	470.00'	214.68'	S 69°42'52" E	110.25'	26°24'13"
C20	62.66'	970.00'	62.65'	S 88°11'29" W	31.34'	3°42'04"
C21	26.41'	970.00'	26.41'	S 85°33'39" W	13.21'	1°33'36"
C22	59.40'	1030.00'	59.39'	S 88°23'24" W	29.71'	3°18'15"
C23	35.18'	1030.00'	35.18'	S 85°45'33" W	17.59'	1°57'26"
C24	50.75'	1030.00'	50.75'	N 86°11'32" E	25.38'	2°49'23"
C25	40.34'	1030.00'	40.33'	N 88°43'33" E	20.17'	2°14'38"
C26	42.73'	970.00'	42.73'	N 86°02'34" E	21.37'	2°31'27"
C27	43.05'	970.00'	43.05'	N 88°34'34" E	21.53'	2°32'34"
C28	79.02'	970.00'	79.00'	S 87°49'06" E	39.53'	4°40'04"
C29	43.48'	970.00'	43.48'	S 84°12'01" E	21.74'	2°34'06"
C30	72.44'	1030.00'	72.42'	S 86°30'57" E	36.23'	4°01'46"
C31	28.49'	1030.00'	28.49'	S 83°42'31" E	14.25'	1°35'05"
C32	50.76'	530.00'	50.74'	S 80°10'20" E	25.40'	5°29'16"
C33	87.14'	530.00'	87.04'	S 72°43'06" E	43.67'	9°25'14"
C34	77.44'	530.00'	77.37'	S 63°49'19" E	38.79'	8°22'18"
C35	28.89'	530.00'	28.89'	S 58°04'28" E	14.45'	3°07'24"
C36	59.81'	470.00'	59.77'	S 79°16'14" E	29.95'	7°17'28"
C37	97.42'	470.00'	97.24'	S 69°41'14" E	48.88'	11°52'32"
C38	59.36'	470.00'	59.32'	S 60°07'52" E	29.72'	7°14'12"
C39	5.39'	70.00'	5.39'	S 02°21'26" E	2.70'	4°24'36"
C40	45.55'	29.00'	41.01'	S 44°57'29" E	29.00'	90°00'00"
C41	45.55'	29.00'	41.01'	N 45°02'31" E	29.00'	90°00'00"
C42	45.55'	29.00'	41.01'	S 45°02'31" W	29.00'	90°00'00"
C43	45.55'	29.00'	41.01'	N 44°57'29" W	29.00'	90°00'00"
C44	11.72'	49.00'	11.70'	N 83°11'17" E	5.89'	13°42'28"
C45	11.72'	49.00'	11.70'	N 83°06'15" W	5.89'	13°42'28"
C46	12.20'	51.00'	12.17'	S 83°10'01" W	6.11'	13°42'28"
C47	12.20'	51.00'	12.17'	S 83°06'15" E	6.13'	13°42'28"
C48	-	-	-	-	-	-
C49	-	-	-	-	-	-
C50	3.43'	130.00'	3.43'	S 00°54'31" E	1.72'	01°30'44"
C51	992.31'	922.00'	945.10'	S 59°12'34" W	550.33'	61°39'54"
C52	37.60'	922.00'	37.60'	S 27°12'32" W	18.80'	02°20'12"
C53	3.43'	130.00'	3.43'	S 00°54'31" E	1.72'	01°30'44"

REV.	BY	DATE	DESCRIPTION
1	BDA	12-13-2023	ISSUE TO CLIENT
2	BDA	12-26-2023	REVISED PER CLIENT COMMENTS - ISSUE FOR SIGNATURES
3	BDA	01-04-2024	REVISED VILLAGE APPROVAL

RAFTER A, LTD
 LAND SURVEYING - ENGINEERING - TESTING
 42853 Oberlin-Elyria Road, Oberlin, Ohio 44074
 440-707-4014 - www.raftera.com - info@raftera.com

WALNUT RIDGE HOLDINGS, LLC
 WALNUT RIDGE DEVELOPMENT, LLC
 3400 TUBER COMANCHE DRIVE
 SANDUSKY, OHIO 44870
 PHONE: (419) 825-4677

WALNUT RIDGE
 PLAT PHASE 1
ENLARGED PLAT VIEW
 VILLAGE OF SHEFFIELD, COUNTY OF LORAIN, STATE OF OHIO

DRAWN BY: BDA
 CHECKED BY: RAF
 RAF JOB No: 2529-21

SHEET: 4 of 5

SURVEY MONUMENTATION NOTE:
 DRILL HOLES OR MAG NAILS HAVE BEEN SET ON THE EXTENSION OF THE PROPERTY LINES ON THE ASPHALT CURB OR IN THE ASPHALT PAVEMENT

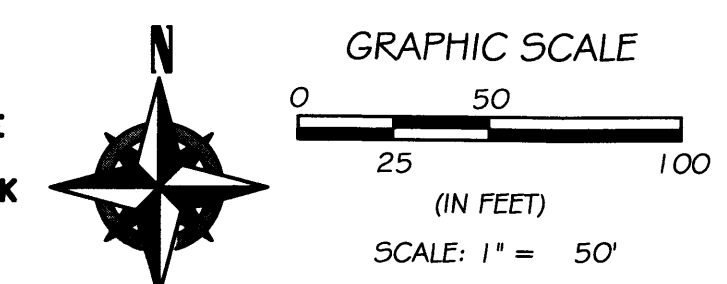

NORFOLK & SOUTHERN RAILROAD

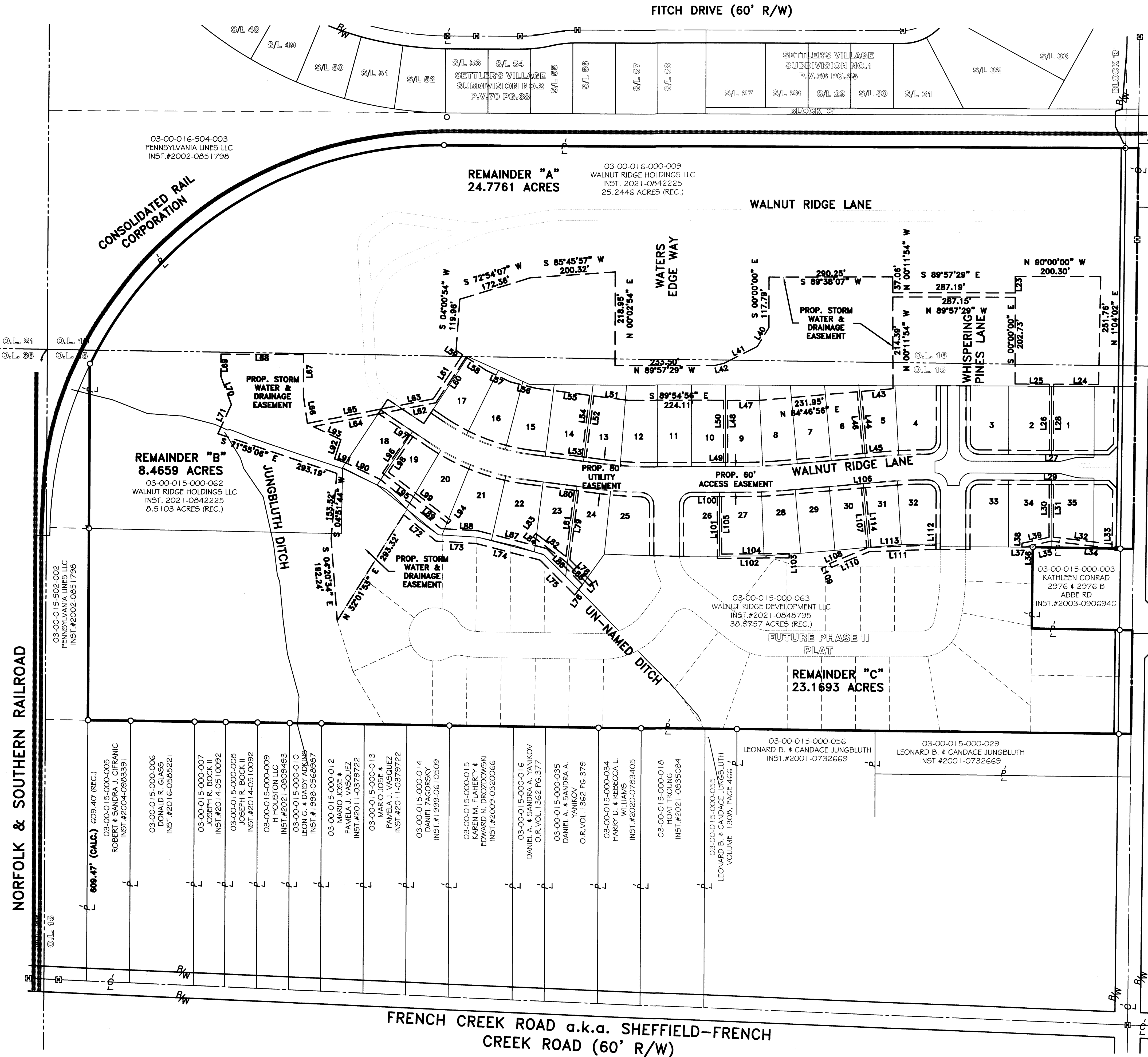

PARCEL LINE TABLE			PARCEL LINE TABLE			PARCEL LINE TABLE		
LINE #	LENGTH	DIRECTION	LINE #	LENGTH	DIRECTION	LINE #	LENGTH	DIRECTION
L-23	36.85'	S 00°00'00" E	L-59	16.30'	S 56°43'01" E	L-87	166.28'	N 75°44'02" W
L-24	105.25'	S 89°57'29" E	L-60	128.90'	S 33°29'14" W	L-88	86.93'	N 86°56'27" W
L-25	80.36'	S 89°57'29" E	L-61	124.71'	N 33°29'14" E	L-89	181.81'	N 51°16'27" W
L-26	154.93'	N 00°02'31" E	L-62	136.40'	S 78°38'11" W	L-90	90.52'	N 64°29'48" W
L-27	10.00'	S 89°57'28" E	L-63	124.13'	N 78°38'11" E	L-91	27.76'	N 71°45'38" W
L-28	154.93'	S 00°02'31" W	L-64	156.63'	S 78°38'11" W	L-92	15.82'	N 18°14'22" E
L-29	10.00'	S 89°57'29" E	L-65	176.74'	N 78°38'11" E	L-93	71.29'	N 65°03'30" W
L-30	122.97'	N 00°02'31" E	L-66	64.54'	N 08°28'51" W	L-94	10.00'	N 37°16'40" E
L-31	123.42'	S 00°02'31" W	L-67	97.24'	N 00°00'00" E	L-95	193.90'	N 52°43'20" W
L-32	138.73'	S 83°11'33" E	L-68	193.15'	N 90°00'00" W	L-96	110.39'	N 34°40'05" E
L-33	10.06'	S 00°38'50" W	L-69	52.84'	S 00°00'00" E	L-97	10.00'	N 56°30'46" W
L-34	143.39'	N 83°11'33" W	L-70	69.52'	S 20°31'31" E	L-98	101.04'	S 34°40'05" W
L-35	60.16'	S 77°16'02" W	L-71	75.30'	S 24°42'15" W	L-99	184.34'	S 52°43'20" E
L-36	0.97'	S 02°09'51" W	L-72	97.62'	S 51°16'27" E	L-100	10.00'	S 89°50'52" W
L-37	10.01'	N 89°57'29" W	L-73	93.64'	S 82°56'27" E	L-101	145.05'	N 00°09'08" W
L-38	9.03'	N 02°09'51" E	L-74	155.14'	S 75°44'02" E	L-102	168.19'	S 89°18'48" W
L-39	52.37'	S 31°34'41" W	L-75	114.92'	S 45°11'22" E	L-103	10.00'	N 00°41'12" W
L-40	86.97'	S 63°09'22" W	L-76	30.36'	N 35°56'42" E	L-104	158.09'	N 89°18'48" E
L-41	23.25'	S 76°35'57" W	L-77	10.00'	S 44°48'38" W	L-105	134.95'	S 00°09'08" E
L-42	26.96'	S 45°15'38" E	L-78	74.06'	S 45°11'22" E	L-106	10.00'	N 84°46'50" E
L-43	74.20'	N 84°46'56" E	L-79	162.95'	S 07°05'02" W	L-107	140.27'	N 05°13'10" W
L-44	144.99'	S 05°13'10" E	L-80	10.00'	S 82°54'58" E	L-108	94.14'	N 67°19'03" W
L-45	10.00'	N 84°46'50" E	L-81	156.71'	N 07°05'02" E	L-109	10.00'	N 22°40'57" W
L-46	144.99'	N 05°13'10" W	L-82	88.86'	S 52°43'51" E	L-110	96.90'	S 67°19'03" W
L-47	72.67'	S 89°54'56" E	L-83	10.00'	S 37°16'09" W	L-111	156.12'	S 87°59'06" W
L-48	145.12'	S 00°09'08" E	L-84	97.22'	S 52°43'51" E	L-112	10.01'	S 00°02'31" W
L-49	10.00'	N 89°50'52" E	L-85	76.19'	N 45°11'22" W	L-113	152.67'	N 87°59'06" E
L-50	145.16'	N 00°09'08" W	L-86	118.44'	N 45°11'22" W	L-114	141.33'	S 05°13'10" E
L-51	80.84'	S 82°53'46" E						
L-52	145.01'	S 07°05'02" W						
L-53	10.00'	S 82°54'58" E						
L-54	145.01'	N 07°05'02" E						
L-55	126.13'	S 82°53'46" E						
L-56	62.92'	S 76°08'12" E						
L-57	62.87'	S 64°42'33" E						
L-58	55.63'	S 56°43'01" E						

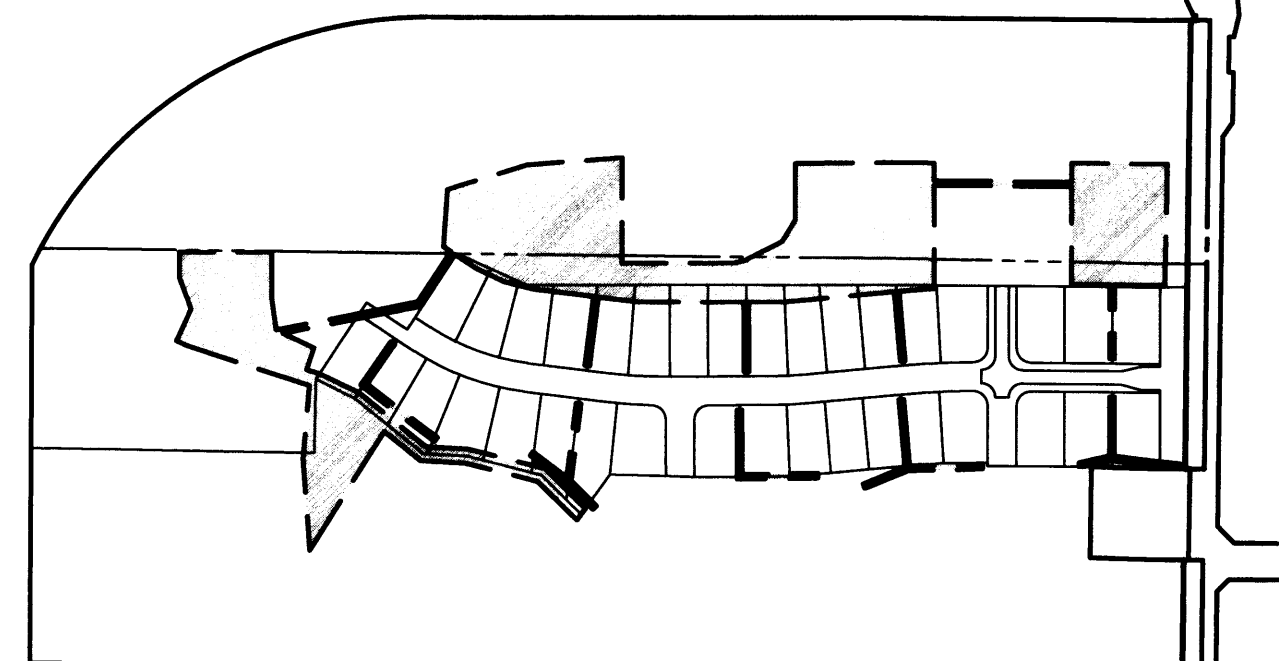

PROP-STORM WATER & DRAINAGE EASEMENT
- NOT TO SCALE -

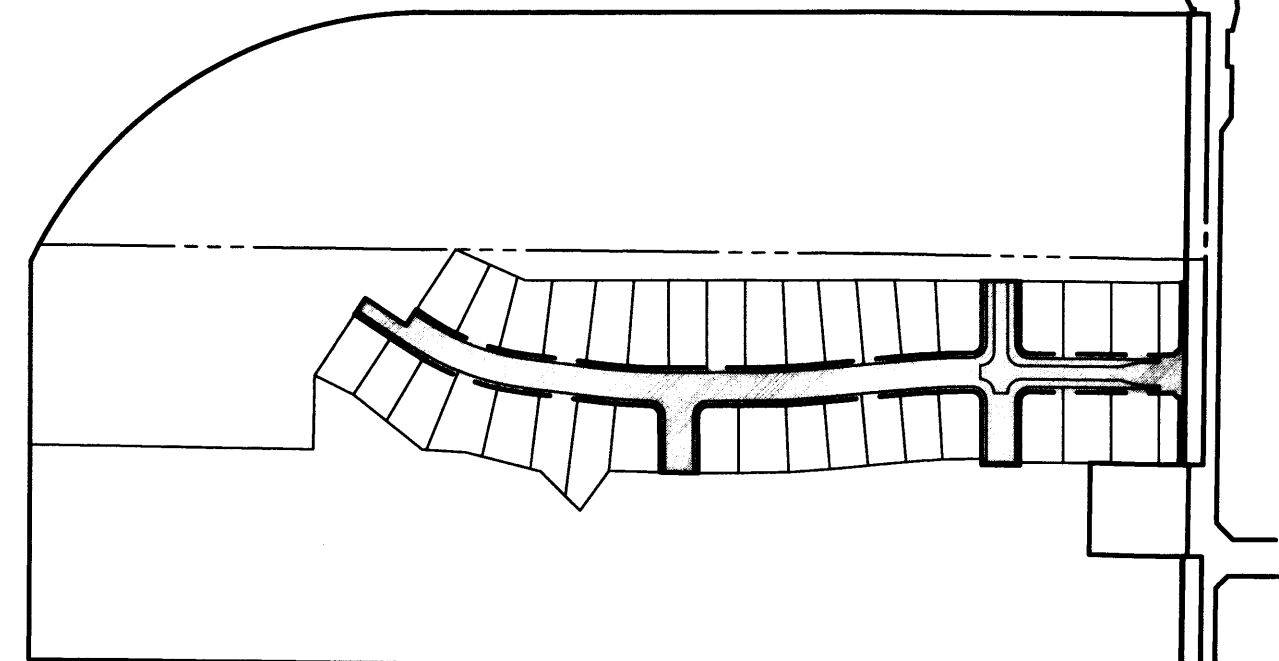

PROP. 80' UTILITY EASEMENT
- NOT TO SCALE -

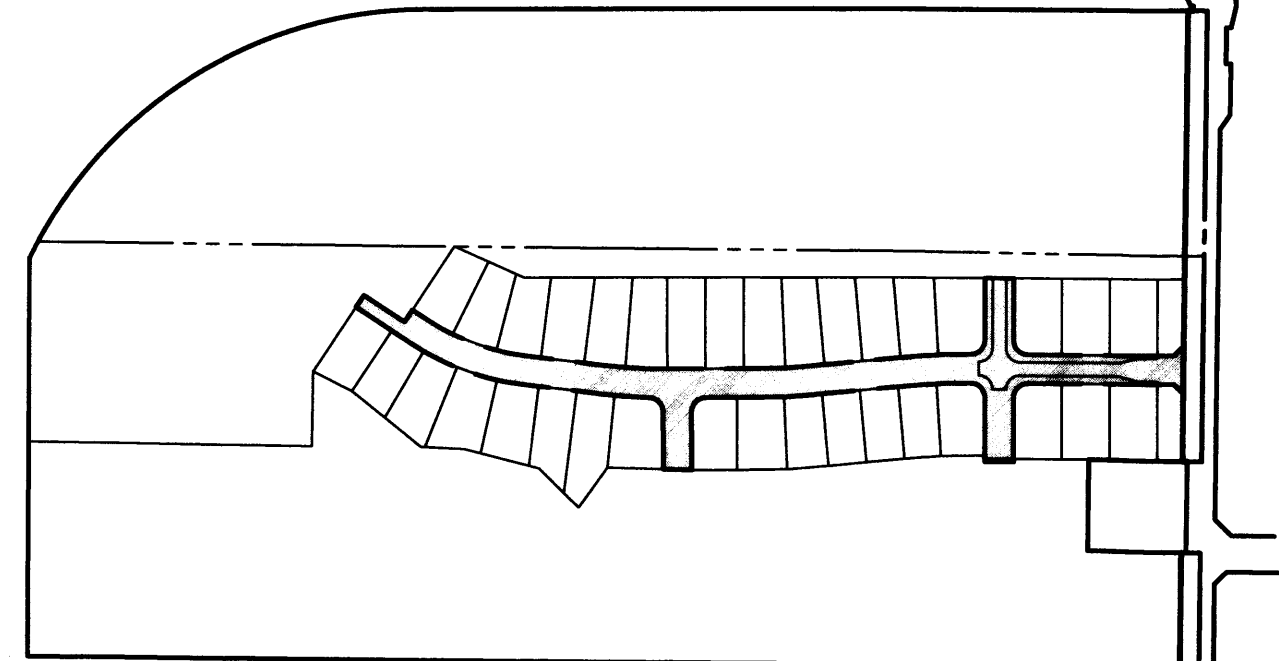

PROP. 60' ACCESS EASEMENT
- NOT TO SCALE -

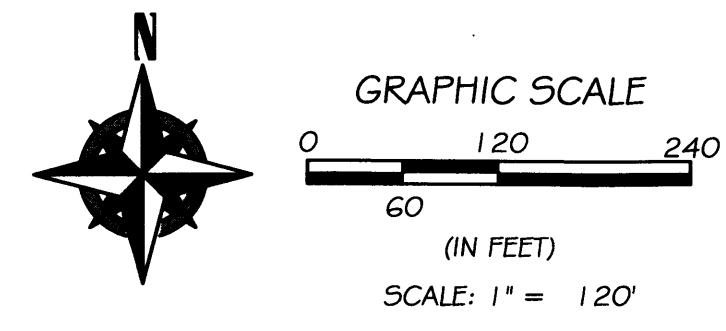

REV.	BY	DATE	DESCRIPTION
1	BDA	12-13-2023	ISSUE TO CLIENT
2	BDA	12-26-2023	REVISED PER CLIENT COMMENTS, ISSUE FOR SIGNATURES
3	BDA	01-04-2024	REVISED VILLAGE APPROVAL

RAFTER A, LTD
LAND SURVEYING - ENGINEERING - TESTING
42653 Oberlin-Elyria Road, Oberlin, Ohio 44074
440-707-4014 - www.raftera.com - info@raftera.com

WALNUT RIDGE DEVELOPMENT, LLC
WALNUT RIDGE CONSTRUCTION, LLC
4400 TIMBER COMMONS DRIVE
LORAIN, OHIO 44042
PHONE: (419) 685-4077

WALNUT RIDGE PLAT PHASE I EASEMENT PLAN
VILLAGE OF SHEFFIELD, COUNTY OF LORAIN, STATE OF OHIO

DRAWN BY: BDA
CHECKED BY: RAF
RAF JOB No: 2529-21

SHEET: 5 of 5