

**GRANTOR/OWNER/DEVELOPER:**

Ridge Water Ltd.  
260 South Logan  
Elyria, Ohio, 44035  
Contact:  
Robert Yost & William Forthofer  
440-366-2241  
bbyost02@gmail.com

# Ridge Water Subdivision No. 4

Being a Re-Subdivision of Sublots 66, 67 & 68 of the Ridge Water Subdivision No. 1 as Recorded in Volume 110, Pages 77-81 and Sublot 93, Blocks D & F of the Ridge Water Subdivision No. 2 as Recorded in Volume 113, Pages 87-89 of Lorain County Plat Records Situated in the City of Elyria, County of Lorain, and State of Ohio, and further known as being part of Lots 16 & 17, West of the Black River, Original Elyria Township, Being Township No. 6 in the 17th Range of Townships in the Connecticut Western Reserve  
Oct., 2023 Scale 1"=60'

**OWNERS CERTIFICATION AND ACCEPTANCE:**

WE, THE UNDERSIGNED, HEREBY CERTIFIES THAT THIS PLAT CORRECTLY REPRESENTS RIDGE WATER SUBDIVISION NO. 4, A SUBDIVISION OF LOTS 149-152 INCLUSIVE AND BLOCKS J & K AND DOES HEREBY ACCEPT THIS PLAT OF THE SAME.

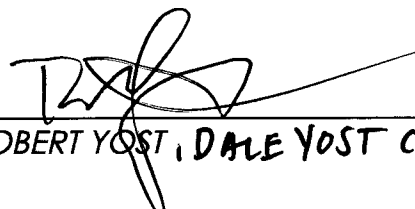
  
ROBERT YOST, DALE YOST CONSTRUCTION CO.  
18

  
WILLIAM FORTHOFFER

**NOTARY:**

STATE OF OHIO )  
COUNTY OF Lorain ) ss:

BEFORE ME, A NOTARY PUBLIC, IN AND FOR SAID COUNTY AND STATE DID PERSONALLY APPEAR, THE ABOVE SIGNED OWNERS WHO ACKNOWLEDGED THE SIGNING OF THIS PLAT TO BE THEIR FREE ACT AND DEED FOR THE PURPOSES THEREIN EXPRESSED.

IN WITNESS WHEREOF, I HAVE HEREUNTO SET MY HAND AND OFFICIAL SEAL AT Elyria OHIO, THIS 27th DAY OF October, 2023

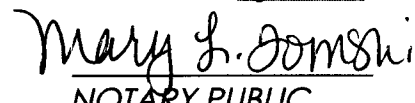
  
MARY L. TOMSKI  
NOTARY PUBLIC

January 6, 2028  
MY COMMISSION EXPIRES

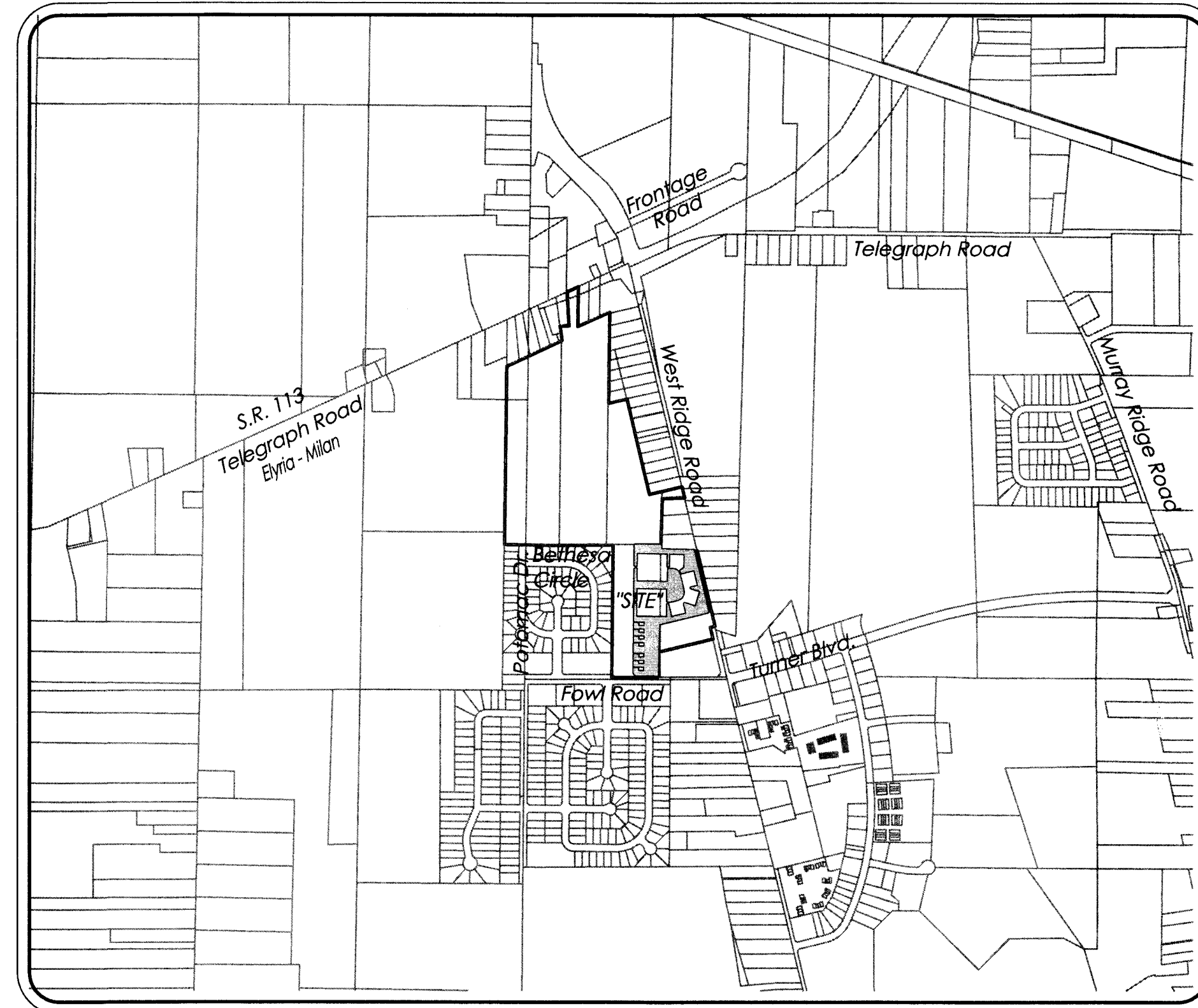
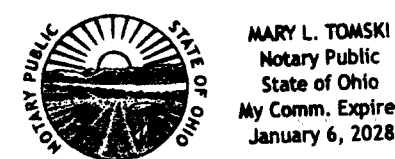

Vicinity Map - Scale 1" = 1000'

**AREA TABULATION:**

AREA IN SUBLOTS = 0.3265 Acres  
AREA IN BLOCK J = 0.4524 Acres  
AREA IN BLOCK K = 0.1717 Acres  
TOTAL AREA = 0.9506 Acres

**ORIGINAL LOT AREA TABULATION:**

AREA IN O.L. 17 = 0.2698 Acres  
BLOCK J = 0.2698 Acres

AREA IN O.L. 16 = 0.1826 Acres  
BLOCK K = 0.1717 Acres  
SUBLOTS = 0.3265 Acres  
TOTAL = 0.6808 Acres

**APPROVALS:**

**CITY ENGINEER:**

APPROVED THIS 27th DAY OF October, 2023, BY THE CITY OF ELYRIA ENGINEER.

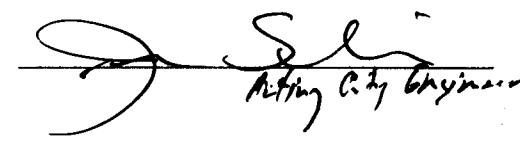

**PLANNING COMMISSION:**

APPROVED THIS 27th DAY OF October, 2023 BY THE CITY OF ELYRIA PLANNING COMMISSION.

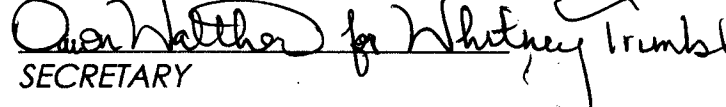
  
PRESIDENT  
  
SECRETARY

**MAYOR:**

APPROVED THIS 27th DAY OF October, 2023 BY THE CITY OF ELYRIA MAYOR.



[Redacted text]

2023-0936320  
PLAT Fee: \$180.00 Page 1 of 3  
Recorded: 11/20/2023 at 11:22 AM  
Receipt: T20230013471  
Lorain County Recorder Mike Doran

Plat Vol 114 Pages 58-59

**BOUNDARY CERTIFICATION:**

I HEREBY CERTIFY THAT I HAVE SURVEYED THE PREMISES AND PREPARED THE ATTACHED PLAT IN ACCORDANCE WITH THE PROVISIONS OF CHAPTER 4733-37 OF THE OHIO ADMINISTRATIVE CODE. THE DIMENSIONS ARE IN FEET AND DECIMAL PARTS THEREOF, ALL OF WHICH ARE CORRECT TO THE BEST OF MY KNOWLEDGE AND BELIEF. IRON MONUMENTS OR PINS AS INDICATED WERE FOUND OR SET AS SHOWN HEREON. THE TERM CERTIFY AS USED IN THIS STATEMENT IS UNDERSTOOD TO BE THE PROFESSIONAL OPINION OF THE SURVEYOR WHICH IS FORMULATED ON HIS BEST KNOWLEDGE, INFORMATION AND BELIEF, AND AS SUCH, IT DOES NOT CONSTITUTE A GUARANTEE OR WARRANTY, EITHER EXPRESSED OR IMPLIED. THIS PLAT WAS PREPARED WITHOUT THE BENEFIT OF AN ABSTRACT OF TITLE AND IS SUBJECT TO ANY STATE OF FACTS REVEALED BY A EXAMINATION OF THE SAME. ALL DIMENSIONS ARE BASED ON THE U.S. SURVEY FOOT DEFINITION. BEARINGS REFER TO THE OHIO STATE COORDINATE SYSTEM OF 1983 (NORTH ZONE). ALL IRON PINS SET ARE 5/8 INCH DIAMETER BY 30-INCH LONG REBAR WITH IDENTIFICATION CHARACTERS SHOWN HEREON (●).

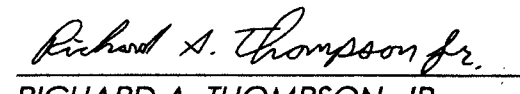
  
RICHARD A. THOMPSON, JR.  
OHIO PROFESSIONAL SURVEYOR #7388  
DATE: 10/24/23

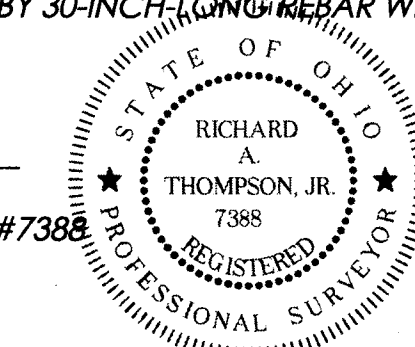

**TRANSFERRED**  
IN COMPLIANCE WITH SEC. 819-202  
OHIO REV. CODE  
NOV 20 2023  
J. CRAIG SNODGRASS, CPA, CGFM  
LORAIN COUNTY AUDITOR

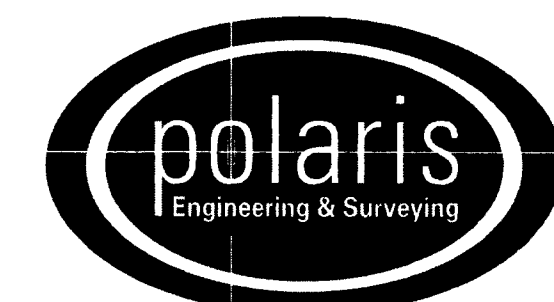
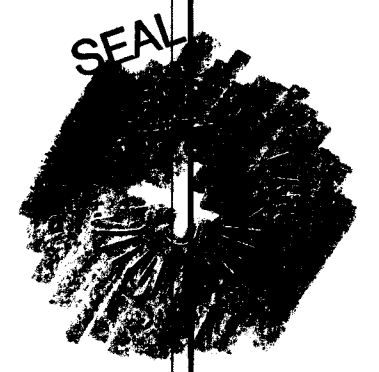

**POLARIS ENGINEERING and SURVEYING, INC.**  
34600 CHARDON ROAD - SUITE D  
WILLOUGHBY HILLS, OHIO 44094  
(440) 944-4433 (440) 944-3722 (Fax)  
www.polaris-es.com

|              |    |
|--------------|----|
| CONTRACT No. |    |
| 19025        |    |
| SHEET        | OF |
| 01           | 02 |

# Ridge Water Subdivision No. 4

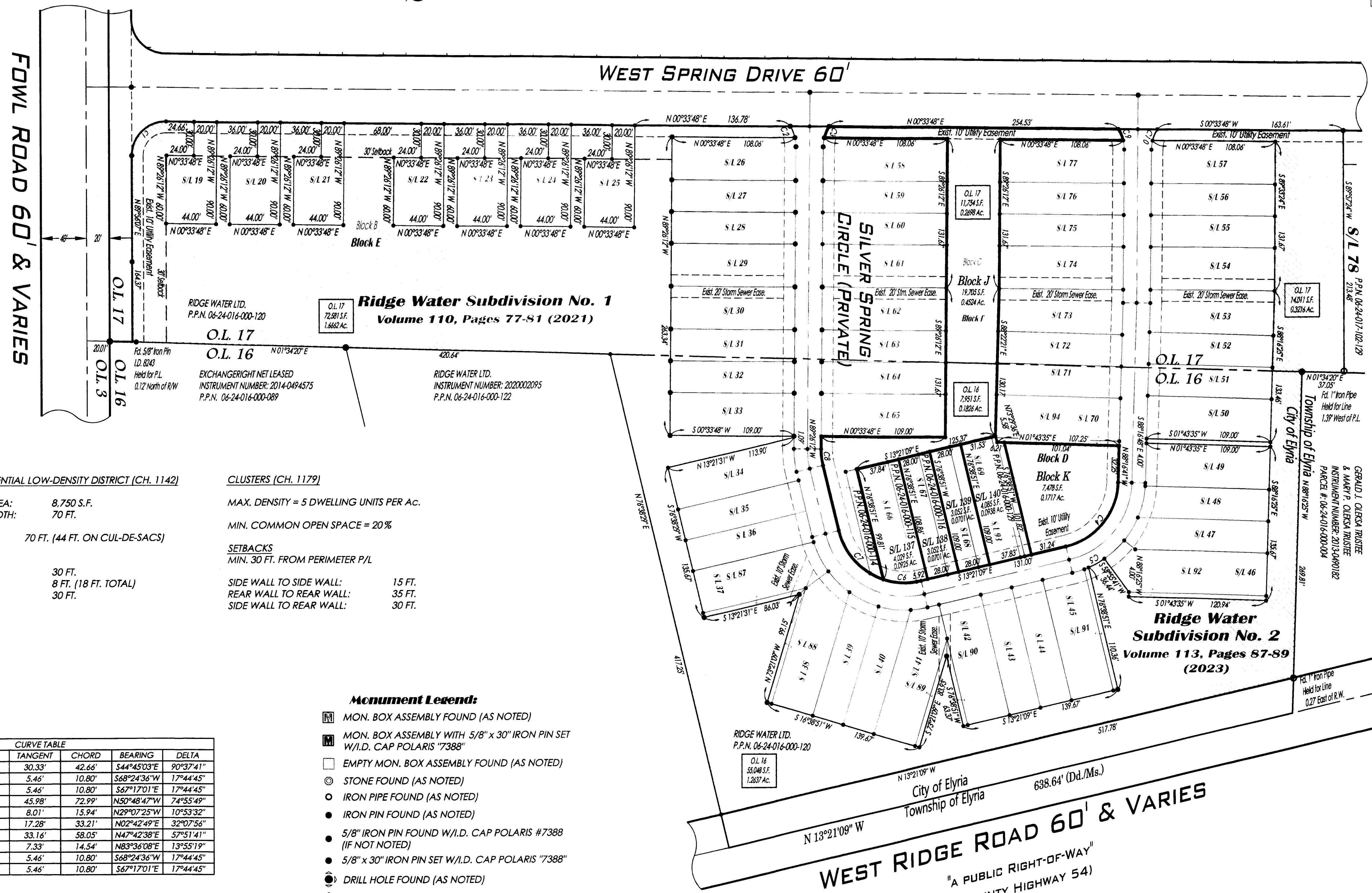
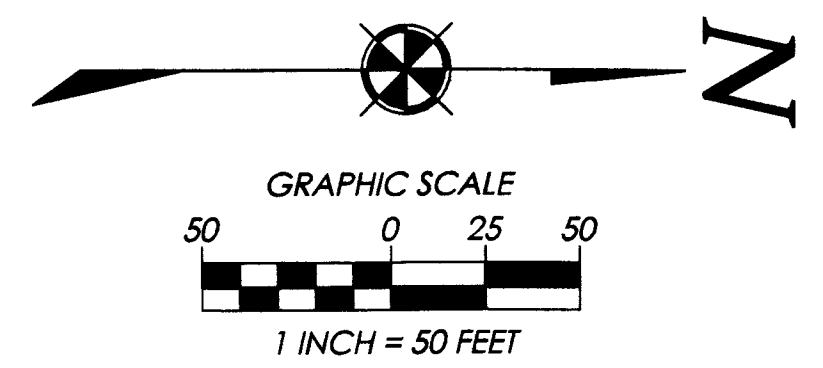

DALE YOST CONSTRUCTION CO.  
 P.P.N. 06-24-016-000-114  
 P.P.N. 06-24-016-000-115  
 P.P.N. 06-24-016-000-116  
 P.P.N. 06-24-016-000-129

RIDGE WATER LTD.  
 P.P.N. 06-24-017-000-098  
 P.P.N. 06-24-017-000-099  
 P.P.N. 06-24-017-000-100  
 P.P.N. 06-24-017-000-101  
 P.P.N. 06-24-017-000-102  
 P.P.N. 06-24-017-000-103  
 P.P.N. 06-24-017-000-104

RIDGE WATER LTD.  
 P.P.N. 06-24-016-000-120

O.L. 17  
 O.L. 16  
 N 01°34'20" E  
 420.64'

EXCHANGERIGHT NET LEASED  
 INSTRUMENT NUMBER: 2014-0494575  
 P.P.N. 06-24-016-000-089

**Ridge Water Subdivision No. 1**  
**Volume 110, Pages 77-81 (2021)**

RIDGE WATER LTD.  
 INSTRUMENT NUMBER: 2020002095  
 P.P.N. 06-24-016-000-122

**Ridge Water Subdivision No. 2**  
**Volume 113, Pages 87-89 (2023)**

**R-LD - RESIDENTIAL LOW-DENSITY DISTRICT (CH. 1142)**

MIN. LOT AREA: 8,750 S.F.  
 MIN. LOT WIDTH: 70 FT.  
 MIN. LOT FRONTAGE: 70 FT. (44 FT. ON CUL-DE-SACS)

**SETBACKS**  
 FRONT: 30 FT.  
 SIDE: 8 FT. (18 FT. TOTAL)  
 REAR: 30 FT.

**CLUSTERS (CH. 1179)**

MAX. DENSITY = 5 DWELLING UNITS PER AC.  
 MIN. COMMON OPEN SPACE = 20%

**SETBACKS**  
 MIN. 30 FT. FROM PERIMETER P/L

SIDE WALL TO SIDE WALL: 15 FT.  
 REAR WALL TO REAR WALL: 35 FT.  
 SIDE WALL TO REAR WALL: 30 FT.

| CURVE TABLE |        |        |         |        |             |           |
|-------------|--------|--------|---------|--------|-------------|-----------|
| CURVE       | LENGTH | RADIUS | TANGENT | CHORD  | BEARING     | DELTA     |
| C1          | 47.45' | 30.00' | 30.33'  | 42.66' | S44°45'03"E | 90°37'41" |
| C2          | 10.84' | 35.00' | 5.46'   | 10.80' | S68°24'36"W | 17°44'45" |
| C3          | 10.84' | 35.00' | 5.46'   | 10.80' | S67°17'01"E | 17°44'45" |
| C4          | 78.46' | 60.00' | 45.98'  | 72.99' | N50°48'47"W | 74°55'49" |
| C5          | 15.97' | 84.00' | 8.01'   | 15.94' | N29°07'25"W | 10°53'32" |
| C6          | 33.65' | 60.00' | 17.28'  | 33.21' | N02°42'49"E | 32°07'56" |
| C7          | 60.59' | 60.00' | 33.16'  | 58.05' | N47°42'38"E | 57°51'41" |
| C8          | 14.58' | 60.00' | 7.33'   | 14.54' | N83°36'08"E | 13°55'19" |
| C9          | 10.84' | 35.00' | 5.46'   | 10.80' | S68°24'36"W | 17°44'45" |
| C10         | 10.84' | 35.00' | 5.46'   | 10.80' | S67°17'01"E | 17°44'45" |

**Monument Legend:**

- ☐ MON. BOX ASSEMBLY FOUND (AS NOTED)
- ☐ MON. BOX ASSEMBLY WITH 5/8" x 30" IRON PIN SET W/I.D. CAP POLARIS "7388"
- ☐ EMPTY MON. BOX ASSEMBLY FOUND (AS NOTED)
- ⊙ STONE FOUND (AS NOTED)
- IRON PIPE FOUND (AS NOTED)
- IRON PIN FOUND (AS NOTED)
- 5/8" IRON PIN FOUND W/I.D. CAP POLARIS #7388 (IF NOT NOTED)
- 5/8" x 30" IRON PIN SET W/I.D. CAP POLARIS "7388"
- ⦿ DRILL HOLE FOUND (AS NOTED)
- ⦿ DRILL HOLE SET
- ▲ P.K. NAIL FOUND (AS NOTED)
- ▲ P.K. NAIL SET

WEST RIDGE ROAD 60' & VARIES  
 "A PUBLIC RIGHT-OF-WAY"  
 (COUNTY HIGHWAY 54)

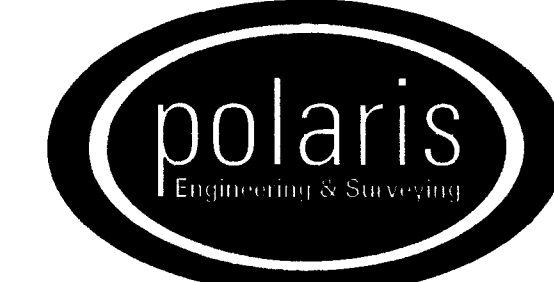

**POLARIS ENGINEERING and SURVEYING, INC.**  
 34600 CHARDON ROAD - SUITE D  
 WILLOUGHBY HILLS, OHIO 44094  
 (440) 944-4433 (440) 944-3722 (Fax)  
 www.polaris-es.com

|              |    |
|--------------|----|
| CONTRACT NO. |    |
| 19025        |    |
| SHEET        | OF |
| 02           | 02 |