

SEE CONTINUATION ON SHEET RP3.0



BLOCK "G"
284,725 SF
6.5364 Ac

12-00-023-000-104
COLUMBIA NORTHWEST PROPERTIES, LLC
#20070185114

BLOCK "H"
826,311 SF
18.9695 Ac
14.3140 Ac O.L. 22
4.6555 Ac O.L. 23

12-00-023-000-104
COLUMBIA NORTHWEST PROPERTIES, LLC
#20070185114

NOTE
BUILDING SETBACKS:
FRONT YARD: 50' MINIMUM
REAR YARD: 40' MINIMUM
SIDE YARD: MINIMUM OF 10 FEET AND 4 FEET;
EITHER SIDE, A COMBINATION
TO EQUAL MIN 14 FEET BETWEEN HOUSES

12-00-023-000-106
KEVIN P PALMER & REBECCA D PALMER
#20180658508

- LEGEND**
- ◻ EXISTING MONUMENT BOX
 - MONUMENT BOX SET
 - IRON PIN SET
 - EXISTING IRON PIPE
 - ⊕ EXISTING RAIL ROAD SPIKE

REDFERN FARMS SUBDIVISION NO. 3
P.V. 64 P. 46

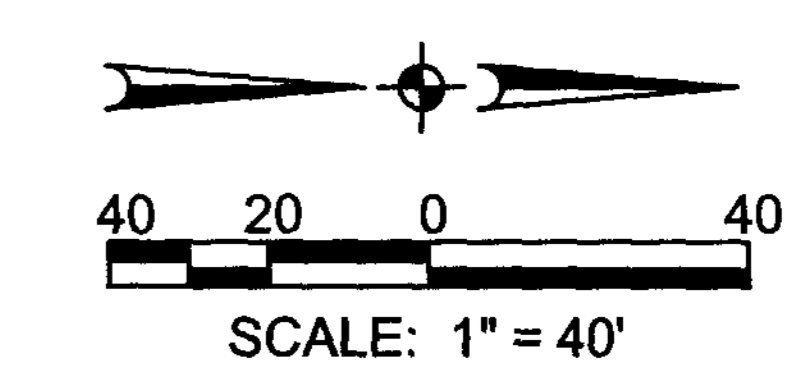

DATE: 08/14/2018	DESCRIPTION: REVISIONS
DRAWN BY: JCC	DATE: 07/11/2019
CHKD BY: JAB	ADDED ACREAGE BREAKDOWN BY O.L.
DWG. NAME: 17024/001A_30/CURRENT DMS/	08/30/2018 ORIGINAL ISSUE
PATN.: KS ASSOCIATES	TAB
F.B.:	TAB

KS ASSOCIATES
KS Associates, Inc.
260 Burns Road, Suite 100
Elyria, OH 44035
P 440 365 4730
F 440 365 4790
www.ksassociates.com

RECORD PLAT
HUNTING MEADOWS
SUBDIVISION NO. 4
TOWNSHIP OF COLUMBIA, PART OF ORIG. LOT NO. 23 AND LOT NO. 23
COUNTY OF LORAIN, STATE OF OHIO

SHEET
RP2.0
OF
4
JOB NO.
17311



12-00-023-000-104
COLUMBIA NORTHWEST PROPERTIES, LLC
#20070185114

BLOCK "G"
284,725 SF
6.5364 Ac

12-00-022-000-083
COLUMBIA NORTHWEST PROPERTIES, LLC
#20070185114

BLOCK "H"
826,311 SF
18,9695 Ac
14,3140 Ac O.L. 22
4,6555 Ac O.L. 23

BLOCK "H"
826,311 SF
18,9695 Ac
14,3140 Ac O.L. 22
4,6555 Ac O.L. 23

LEGEND

- EXISTING MONUMENT BOX
- MONUMENT BOX SET
- IRON PIN SET
- EXISTING IRON PIPE
- ◇ EXISTING RAIL ROAD SPIKE

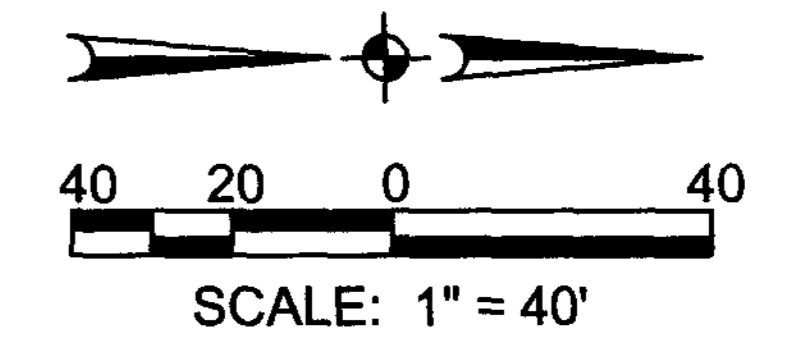

12-00-022-000-021
FREDERICK E. GILLILAND &
MARY JANE GILLILAND, TRUSTEES
#20170650083

KS Associates, Inc.
260 Burns Road, Suite 100
Elyria, OH 44035
P 440 365 4730
F 440 365 4790
www.ksassociates.com



**SUBDIVISION PLAN
HUNTING MEADOWS
SUBDIVISION NO. 4**

SHEET
RP3.0

OF
4
JOB NO.

DATE	DESCRIPTION	BY
08/11/2018	ADD ACRES BREAKDOWN BY O.L.	TAB
08/30/2018	ORIGINAL ISSUE	TAB

DATE	DRAWN BY	CHECKED BY	DATE
08/11/2018	TAB	TAB	

TOWNSHIP OF COLUMBIA, PART OF ORIG. LOT NO. 22 AND LOT NO. 23
COUNTY OF LORAIN, STATE OF OHIO

12-00-022-000-021
FREDERICK E. GILLILAND & MARY JANE GILLILAND, TRUSTEES
#20170650083

12-00-022-000-034
RIVERSIDE DEVELOPMENT, INC. &
CMK, LTD.
#20140511080

12-00-022-000-083
COLUMBIA NORTHWEST PROPERTIES, LLC
#20070185114

BLOCK "H"
826,311 SF
18,9695 ACRES
14.3140 Ac O.L. 22
4.6555 Ac O.L. 23

BLOCK "G"
284,725 SF
6.5364 ACRES
12-00-023-000-104
COLUMBIA NORTHWEST PROPERTIES, LLC
#20070185114

12-00-023-000-106
KEVIN P PALMER & REBECCA D PALMER
#20180658508



100 0 100 200
SCALE IN FEET
SCALE 1"=100'

CURVE TABLE						
CURVE #	LENGTH	RADIUS	DELTA	CHORD DIRECTION	CHORD LENGTH	TANGENT
C1	221.00'	150.00'	84°24'58"	S43°40'01"W	201.55'	136.05'
C2	176.80'	120.00'	84°24'58"	N43°40'01"E	161.24'	108.84'
C3	265.20'	180.00'	84°24'58"	S43°40'01"W	241.86'	163.26'
C4	174.09'	150.00'	66°29'47"	N31°47'22"W	164.48'	98.34'
C5	208.90'	180.00'	66°29'47"	S31°47'22"E	197.38'	118.00'
C6	139.27'	120.00'	66°29'47"	N31°47'22"W	131.58'	78.67'
C7	314.77'	400.00'	45°05'16"	S42°29'37"E	306.71'	166.04'
C8	291.16'	370.00'	45°05'16"	S42°29'37"E	283.71'	153.59'
C9	181.36'	430.00'	24°09'57"	N52°57'16"W	180.02'	92.05'
C10	44.25'	430.00'	5°53'46"	N22°53'51"W	44.23'	22.14'
C11	45.28'	30.00'	86°28'15"	N17°23'23"E	41.10'	28.21'
C12	41.10'	30.00'	78°30'11"	N80°07'23"W	37.96'	24.51'
C13	45.88'	150.00'	17°31'36"	N28°42'47"W	45.71'	23.12'
C14	55.06'	180.00'	17°31'36"	N28°42'46"W	54.85'	27.75'
C15	36.71'	120.00'	17°31'36"	N28°42'46"W	36.56'	18.50'
C16	37.82'	50.00'	43°20'30"	S15°48'19"E	36.93'	19.87'
C17	37.82'	50.00'	43°20'30"	N59°08'49"W	36.93'	19.87'
C18	279.27'	60.00'	266°41'01"	S52°31'26"W	87.27'	63.58'
C19	92.18'	150.00'	35°12'40"	N78°13'51"E	90.74'	47.60'
C20	73.75'	120.00'	35°12'40"	N78°13'51"E	72.59'	38.08'
C21	113.69'	185.00'	35°12'40"	S78°13'51"W	111.91'	58.71'
C22	13.71'	60.00'	13°05'47"	N0°40'57"W	13.68'	6.89'
C23	62.18'	60.00'	59°22'31"	N36°55'06"W	59.43'	34.21'
C24	54.19'	60.00'	51°44'39"	S87°31'18"W	52.36'	29.10'
C25	54.19'	60.00'	51°44'39"	S35°46'39"W	52.36'	29.10'
C26	79.22'	60.00'	75°38'52"	S27°55'06"E	73.59'	46.58'
C27	15.79'	60.00'	15°04'33"	S73°16'48"E	15.74'	7.94'
C28	47.07'	370.00'	7°17'22"	S23°35'39"E	47.04'	23.57'
C29	156.51'	370.00'	24°14'13"	S39°21'27"E	155.35'	79.45'
C30	87.58'	370.00'	13°33'42"	S58°15'24"E	87.37'	43.99'
C31	29.23'	430.00'	3°53'40"	S63°05'25"E	29.22'	14.62'
C32	86.14'	430.00'	11°28'42"	S55°24'14"E	86.00'	43.22'
C33	65.99'	430.00'	8°47'35"	S45°16'05"E	65.93'	33.06'
C34	52.55'	180.00'	16°43'33"	N56°40'29"W	52.36'	26.46'
C35	56.58'	180.00'	18°00'36"	N39°18'24"W	56.35'	28.53'
C36	55.79'	180.00'	17°45'29"	N21°25'22"W	55.57'	28.12'
C37	43.99'	180.00'	14°00'09"	N5°32'33"W	43.88'	22.11'
C38	96.27'	120.00'	45°58'00"	N21°31'28"W	93.71'	50.90'
C39	43.00'	120.00'	20°31'47"	N54°46'21"W	42.77'	21.73'
C40	54.20'	180.00'	17°15'05"	N10°05'04"E	53.99'	27.30'
C41	55.79'	180.00'	17°45'29"	N27°35'21"E	55.57'	28.12'
C42	56.58'	180.00'	18°00'36"	N45°28'23"E	56.35'	28.53'
C43	55.79'	180.00'	17°45'29"	N63°21'26"E	55.57'	28.12'
C44	42.85'	180.00'	13°38'20"	N79°03'20"E	42.75'	21.53'
C45	56.09'	185.00'	17°22'20"	N86°02'26"E	55.88'	28.26'
C46	54.02'	185.00'	16°43'45"	N68°59'24"E	53.82'	27.20'
C47	23.76'	120.00'	11°20'47"	S89°50'12"E	23.73'	11.92'
C48	49.98'	120.00'	23°51'53"	S72°33'28"W	49.62'	25.36'
C49	14.46'	50.00'	16°34'00"	N02°25'04"W	14.41'	7.28'
C50	23.37'	50.00'	26°46'31"	S24°05'19"E	23.15'	11.90'
C51	3.58'	185.00'	1°06'35"	S84°43'06"E	3.58'	1.79'
C52	217.26'	400.00'	31°07'10"	S49°28'40"E	214.59'	111.38'
C53	97.52'	400.00'	13°58'06"	S26°56'02"E	97.28'	49.00'
C54	142.28'	220.00'	37°03'19"	N4°25'46"W	139.81'	73.73'

BY	
DATE	08/14/2018
DESCRIPTION	
REVISIONS	
DATE	08/14/2018
DRAWN BY	CCC
CHECKED BY	TAB
DWG. NAME	07/11/2019 ADDED ACREAGE BREAKDOWN BY O.L.
PAT. NO.	08/30/2018 ORIGINAL ISSUE
F.B.	
<p>KS Associates, Inc. 260 Burns Road, Suite 100 Elyria, OH 44035 P 440 365 4730 F 440 365 4790 www.ksassociates.com</p>	
<p>KS ASSOCIATES</p>	
<p>CURVE DATA TABLES & BLOCKS G & H HUNTING MEADOWS SUBDIVISION NO. 4</p>	
<p>TOWNSHIP OF COLUMBIA, PART OF ORIG. LOT NO. 22 AND LOT NO. 23 COUNTY OF LORAIN, STATE OF OHIO</p>	
SHEET	RP4.0
OF	4
JOB NO.	17311

Plat Sheet

Instrument # 2019-0725134 Film #

Name of Plat: Hunting Meadows Subdivision No. 4.

Owner: Columbia Northwest Properties LLC

Description: Situated in the State of Ohio,
County of Lorain, Township of Columbia
Being Part of Original Lots 22 and 23
46.4545 Acres Creating Sublots 80 thru
130 and Blocks 9 and H.
Utility Easements also

Floor Plans:

Related/Margin:

Comments:

Vol. 106

Pg. 93, 94, 95, 96.

Amount: 345.60

Initials: TM

Receiving Stamp

OLD REPUBLIC NATIONAL TITLE
INSURANCE CO
160 CLEVELAND STREET
ELYRIA, OH 44035